



**IB-51056 PowlVac[®] ARM
Automatic Racking Vacuum Circuit Breaker**

5kV & 15kV
1200A, 2000A, & 3000A

Contact Information

Powell Electrical Systems, Inc.

www.powellind.com

info@powellind.com

Service Division

PO Box 12818

Houston, Texas 77217-2818

Tel: 713.944.6900

Fax: 713.948.4569



Signal Words

As stated in ANSI Z535.4-2002, § 4.13-4.13.3 the signal word is a word that calls attention to the safety sign and designates a degree or level of hazard seriousness. The signal words for product safety signs are “**Danger**”, “**Warning**”, and “**Caution**”. These words are defined as:



DANGER

DANGER indicates an imminently hazardous situation which, if not avoided, will result in death or serious injury.



WARNING

WARNING indicates a potentially hazardous situation which, if not avoided, could result in death or serious injury.



CAUTION

CAUTION indicates a potentially hazardous situation which, if not avoided, may result in minor or moderate injury.

Not stated in ANSI Z535.4-2002, § 4.13-4.13.3 as a signal word but used in this manual is “**IMPORTANT**”. This is defined as:



IMPORTANT

IMPORTANT indicates a section of the manual covering a non hazardous situation, but one where Powell feels proper attention is warranted.

Qualified Person

For the purposes of this manual, a qualified person, as stated in NFPA 70®, is one familiar with the construction and operation of the equipment and the hazards involved.

In addition to the above qualifications, one must also be:

1. trained and authorized to energize, deenergize, clear, ground, and tag circuits and equipment in accordance with established safety practices.
2. trained in the proper care and use of personal protective equipment (PPE) such as rubber gloves, hard hat, safety glasses or face shields, flash clothing, etc., in accordance with established safety practices.
3. trained in rendering first aid if necessary.

This page is intentionally left blank.



Contents

Ch 1	General Information.....	1
A.	SCOPE	2
B.	PURPOSE.....	2
C.	INSTRUCTION BULLETINS AVAILABLE ELECTRONICALLY.....	2
Ch 2	Safety.....	3
A.	SAFE WORK CONDITION	3
B.	SAFETY GUIDELINES	3
C.	GENERAL.....	4
D.	SPECIFIC.....	4
E.	X-RAYS	5
F.	SAFETY LABELS.....	5
Ch 3	Equipment Description.....	6
A.	GENERAL.....	6
B.	THE STORED ENERGY MECHANISM.....	6
1)	Mechanical Description.....	6
2)	Electrical Description.....	16
C.	AUTOMATIC RACKING MECHANISM.....	17
1)	General Description.....	17
2)	Racking Mechanism	18
D.	CIRCUIT BREAKER COMPARTMENT INTERFACES.....	19
1)	Primary Disconnecting Devices.....	19
2)	Secondary Disconnecting Devices.....	19
3)	MOC (Mechanism Operated Cell Switch) Actuator.....	19
4)	TOC (Truck Operated Cell Switch) Actuator.....	19
5)	Ground Connection	19
6)	Shutter Rollers.....	20
7)	Anti-Rollout Latch.....	20
E.	VACUUM INTERRUPTERS	20
F.	VACUUM INTERRUPTER CONNECTION.....	20

Contents

Ch 4 Installation.....	21
A. RECEIVING	21
B. HANDLING.....	21
C. STORAGE.....	22
D. PLACING THE CIRCUIT BREAKER INTO SERVICE.....	23
1) <i>High Voltage Insulation Integrity.....</i>	<i>23</i>
2) <i>Vacuum Integrity.....</i>	<i>24</i>
3) <i>Control Voltage Insulation Integrity.....</i>	<i>25</i>
4) <i>Mechanical Operation Check.....</i>	<i>26</i>
5) <i>Electrical Operation Check.....</i>	<i>27</i>
6) <i>Emergency Racking Mechanism Check.....</i>	<i>27</i>
E. INSERTING THE CIRCUIT BREAKER INTO THE CIRCUIT BREAKER COMPARTMENT.....	28
1) <i>Prior to Inserting the Circuit Breaker into the Circuit Breaker Compartment.....</i>	<i>29</i>
2) <i>Inserting the Circuit Breaker to the Test/Disconnected Position.....</i>	<i>30</i>
3) <i>Inserting the Circuit Breaker to the Connected Position.....</i>	<i>31</i>
F. REMOVING THE CIRCUIT BREAKER FROM THE CIRCUIT BREAKER COMPARTMENT	32
1) <i>Removing the Circuit Breaker from the Connected to the Test/Disconnected Position.....</i>	<i>32</i>
2) <i>Removing the Circuit Breaker from the Test/Disconnected Position out of the Circuit Breaker Compartment.....</i>	<i>33</i>
 Ch 5 Maintenance.....	 34
A. GENERAL DESCRIPTION	34
1) <i>Introduction.....</i>	<i>34</i>
2) <i>Inspection and Cleaning</i>	<i>35</i>
B. MECHANISM AREA	35
1) <i>Mechanical Operation</i>	<i>35</i>
2) <i>Lubrication.....</i>	<i>36</i>
3) <i>Closing Spring Removal.....</i>	<i>40</i>
4) <i>Slow Closing of Mechanism.....</i>	<i>41</i>
5) <i>Mechanism Adjustments.....</i>	<i>41</i>
6) <i>Electrical Operation</i>	<i>46</i>
C. VACUUM INTERRUPTER AND CONTACT AREA	46
1) <i>Vacuum Interrupter and Contact Erosion</i>	<i>46</i>
2) <i>Vacuum Integrity.....</i>	<i>46</i>
3) <i>Mechanical Adjustment of Vacuum Interrupters</i>	<i>46</i>
D. OPTIONAL MAINTENANCE PROCEDURES	46
1) <i>High Potential Tests</i>	<i>46</i>
2) <i>Timing.....</i>	<i>47</i>
3) <i>Primary Resistance Check</i>	<i>47</i>



Contents

Ch 6	<i>Recommended Renewal Parts and Replacement Procedures</i>	48
A.	ORDERING INSTRUCTIONS	48
B.	RECOMMENDED RENEWAL PARTS	48
C.	REPLACEMENT PROCEDURES	48
1)	Vacuum Interrupter Assembly	49
2)	Sliding Contact Finger Assembly	49
3)	Closing Coil Assembly	49
4)	Primary Shunt Trip Coil Assembly	49
5)	Secondary Shunt Trip Coil Assembly	49
6)	Undervoltage Device Assembly (UV)	49
7)	Charging Motor Assembly	49
8)	Anti-Pump Relay Assembly	49
9)	Latch Check Switch	49
10)	Motor Cutoff Switch Assembly	50
11)	Auxiliary Switch	50
12)	Primary Disconnecting Device Spring Assembly	50

Figures

Figure 1	<i>PowIVac® ARM Vacuum Circuit Breaker Front View with Cover</i>	<i>7</i>
Figure 2	<i>PowIVac® ARM Vacuum Circuit Breaker with Front Cover Removed</i>	<i>8</i>
Figure 3	<i>PowIVac® ARM Vacuum Circuit Breaker Rear View Without Barriers</i>	<i>9</i>
Figure 4	<i>Cam and Fundamental Linkage Positions</i>	<i>11</i>
Figure 5	<i>Mechanism and Trip Linkages</i>	<i>12</i>
Figure 6	<i>Operation Sequence</i>	<i>14</i>
Figure 7	<i>Typical AC/DC Control Scheme</i>	<i>15</i>
Figure 8	<i>Circuit Breaker with Shipping Bracket</i>	<i>21</i>
Figure 9	<i>Circuit Breaker on Crane.....</i>	<i>22</i>
Figure 10	<i>Circuit Breaker in Shipping Carton.....</i>	<i>22</i>
Figure 11	<i>Secondary Disconnect Override Device</i>	<i>26</i>
Figure 12	<i>Secondary Disconnecting Device</i>	<i>30</i>
Figure 13	<i>Circuit Breaker in Test Position.....</i>	<i>31</i>
Figure 14	<i>Lubrication.....</i>	<i>38</i>
Figure 15	<i>Lubrication (cont)</i>	<i>39</i>
Figure 16	<i>Main Closing Spring Assembly Compressed for Removal.....</i>	<i>40</i>
Figure 17	<i>Main Closing Spring Assembly Installed</i>	<i>40</i>
Figure 18	<i>Primary Trip Prop Adjustment.....</i>	<i>42</i>
Figure 19	<i>Feeler Gauge</i>	<i>43</i>
Figure 20	<i>Latch Check Switch Adjustment</i>	<i>44</i>
Figure 21	<i>Primary Current Path.....</i>	<i>51</i>
Figure 22	<i>Control Devices</i>	<i>53</i>



Tables

Table A Field Dielectric Test Values.....	23
Table B Lubrication	37
Table C Timing.....	47
Table D Primary Resistance	47
Table E Primary Current Path	51
Table F Control Devices.....	52
Table G Miscellaneous Parts.....	54

This page is intentionally left blank.



Ch 1 General Information



WARNING

The equipment described in this document may contain high voltages and currents which can cause serious injury or death.

The equipment is designed for use, installation, and maintenance by knowledgeable users of such equipment having experience and training in the field of high voltage electricity. This document and all other documentation shall be fully read, understood, and all warnings and cautions shall be abided by. If there are any discrepancies or questions, the user shall contact Powell immediately at 1.800.480.7273.



WARNING

Before any adjustment, servicing, part replacement, or any other act is performed requiring physical contact with the electrical working components or wiring of this equipment, the power supply must be disconnected. Failure to follow this warning may result in injury or death.



IMPORTANT

The information in this instruction bulletin is not intended to explain all details or variations of the Powell equipment, nor to provide for every possible contingency or hazard to be met in connection with installation, testing, operation, and maintenance of the equipment. For additional information and instructions for particular problems, which are not presented sufficiently for the user's purposes, contact Powell at 1.800.480.7273.



IMPORTANT

Powell reserves the right to discontinue and to change specifications at any time without incurring any obligation to incorporate new features in products previously sold.

A. SCOPE

The information in this instruction bulletin describes the following PowlVac® ARM vacuum circuit breakers:

- 05PV36ARM
- 05PV50ARM
- 15PV25ARM
- 15PV36ARM
- 15PV50ARM

B. PURPOSE

The information in this instruction bulletin is intended to provide information required to properly operate and maintain the PowlVac ARM vacuum circuit breaker described in **Ch 1 General Information, A. SCOPE**.

This instruction bulletin provides:

1. Safety guidelines
2. General descriptions of the operation and maintenance of the PowlVac ARM vacuum circuit breaker
3. Instructions for installation and placing the circuit breaker into service
4. Instructions for part replacement
5. Information for ordering renewal parts
6. Procedure for critical adjustments
7. Illustrations, photographs, and description of the circuit breaker

The illustrations contained in this document may not represent the exact construction details of each particular type of PowlVac ARM vacuum circuit breaker. The illustrations in this document are provided as general information to aid in showing component locations only.

All illustrations and photos are shown using deenergized equipment.



WARNING

Be sure to follow the appropriate safety precaution while handling any of the equipment. Failure to do so may result in serious injury or death.

To the extent required, the products described herein meet the applicable ANSI, IEEE, and NEMA Standards; however, no such assurance is given with respect to local codes and ordinances which may vary greatly.

C. INSTRUCTION BULLETINS AVAILABLE ELECTRONICALLY

For more information visit www.powellind.com. To contact the Powell Service Division call 1.800.480.7273 or 713.944.6900, or email info@powellservice.com.



Ch 2 Safety

A. SAFE WORK CONDITION

The information in Section A is quoted from *NFPA 70E 2004 - Article 120, 120.1 Establishing an Electrically Safe Work Condition*.

120.1 Process of Achieving an Electrically Safe Work Condition

1. Determine all possible sources of electrical supply to the specific equipment. Check applicable up-to-date drawings, diagrams, and identification tags.
2. After properly interrupting the load current, OPEN the disconnecting device(s) for each source.
3. Wherever possible, visually verify that all blades of the disconnecting devices are fully OPEN or that drawout type circuit breakers are withdrawn to the fully disconnected position.
4. Apply lockout/tagout devices in accordance with a documented and established policy.
5. Use an adequately rated voltage detector to test each phase conductor or circuit part to verify they are deenergized. Test each phase conductor or circuit part both phase-to-phase, and phase-to-ground. Before and after each test, determine that the voltage detector is operating satisfactorily.
6. Where the possibility of induced voltages or stored electrical energy exists, ground the phase conductors or circuit parts before touching them. Where it could be reasonably anticipated that the conductors or circuit parts being deenergized could contact other exposed energized conductors or circuit parts, apply ground connecting devices rated for the available fault duty.

B. SAFETY GUIDELINES

Study this instruction bulletin and all other associated documentation before uncrating the circuit breakers.

Each user has the responsibility to instruct and supervise all personnel associated with usage, installation, operation, and maintenance of this equipment on all safety procedures.

Furthermore, each user has the responsibility of establishing a safety program for each type of equipment encountered.

The circuit breakers described in this instruction bulletin are operated by a high-energy, high-speed mechanism that is interlocked to provide specific operating sequences. It is mandatory that the following rules be observed to ensure the safety of personnel associated with usage, installation, operation, and maintenance of these circuit breakers.

The safety rules in this instruction bulletin are not intended to be a complete safety program. The rules are intended to cover only some of the important aspects of personnel safety related to PowIVac® ARM vacuum circuit breakers.

C. GENERAL

1. Only supervised and qualified personnel trained in the usage, installation, operation, and maintenance of the circuit breaker shall be allowed to work on this equipment. It is mandatory that this instruction bulletin, any supplements, and service advisories be studied, understood, and followed.
2. Maintenance programs must be consistent with both customer experience and manufacturer's recommendations, including service advisories and instruction bulletin(s). A well planned and executed routine maintenance program is essential for circuit breaker reliability and safety.
3. Service conditions and circuit breaker applications shall also be considered in the development of safety programs. Variables include ambient temperature; humidity; actual continuous current; thermal cycling; number of operations; interrupting duty; and any adverse local conditions including excessive dust, ash, corrosive atmosphere, vermin and insect infestations.

D. SPECIFIC

1. **DO NOT WORK ON AN ENERGIZED CIRCUIT BREAKER.** If work must be performed on a circuit breaker, remove it from service and remove it from the metal-clad switchgear.
2. **DO NOT WORK ON A CIRCUIT BREAKER WITH THE CONTROL CIRCUIT ENERGIZED.**
3. **EXTREME CARE MUST BE EXERCISED TO KEEP ALL PERSONNEL, TOOLS, AND OTHER OBJECTS CLEAR OF MECHANISMS WHICH ARE TO BE OPERATED, DISCHARGED, OR RELEASED.** These circuit breakers utilize stored energy mechanisms. These mechanisms must be serviced only by skilled and knowledgeable personnel capable of releasing each spring load in a controlled manner. Detailed

information regarding these mechanisms is found in this instruction bulletin.

4. **DO NOT ATTEMPT TO CLOSE THE CIRCUIT BREAKER MANUALLY ON AN ENERGIZED CIRCUIT.**
5. **DO NOT USE AN OPEN CIRCUIT BREAKER AS THE SOLE MEANS OF ISOLATING A HIGH VOLTAGE CIRCUIT.** For complete isolation, the circuit breaker shall be in the disconnected position or shall be withdrawn completely.
6. **ALL COMPONENTS SHALL BE DISCONNECTED BY MEANS OF A VISIBLE BREAK AND SECURELY GROUNDED FOR SAFETY OF PERSONNEL PERFORMING MAINTENANCE OPERATIONS ON THE CIRCUIT BREAKERS.**
7. Interlocks are provided to ensure the proper operating sequences of the circuit breakers and for the safety of the user. If for any reason an interlock does not function as described, do not make any adjustments, modification, or deform the parts. **DO NOT FORCE THE PARTS INTO POSITION. CONTACT POWELL FOR INSTRUCTIONS.**



E. X-RAYS

When high voltage is applied across the contacts of a vacuum interrupter, there is the possibility of generation of X-rays. The intensity of the X-radiation is dependent on the peak voltage and the contact gap. At the normal operating voltage for this type of equipment, the radiation levels are negligible. At the voltages specified for testing, test personnel shall be in front of the circuit breaker such that the two layers of steel used in the frame and front cover construction are between the test personnel and the vacuum interrupters, and that the test personnel be no closer than one meter (3') from the front of the circuit breaker. **THE CIRCUIT BREAKER SHALL BE EITHER FULLY OPEN, OR FULLY CLOSED WHEN MAKING HIGH POTENTIAL TESTS. DO NOT TEST WITH CONTACTS PARTIALLY OPEN.**

F. SAFETY LABELS

The equipment described in this document has **DANGER, WARNING, CAUTION**, and instruction labels attached to various locations. All equipment **DANGER, WARNING, CAUTION**, and instruction labels shall be observed when the circuit breaker is handled, operated, or maintained.



Warning and Caution labels are located in various places in and on the switchgear and on the circuit breaker removable element. Always observe these warnings and caution labels. Do NOT remove or deface any of these warning/caution labels.

Ch 3 Equipment Description

A. GENERAL

PowlVac® ARM circuit breakers use sealed vacuum interrupters (Figure 3, f) to control the primary circuit. The primary connections to the associated metal-clad switchgear are made by parallel copper busbars terminating in multiple contact fingers of the primary disconnecting devices (Figure 3, c & g). The primary disconnecting devices, busbars, and vacuum interrupter assemblies are supported by insulators (Figure 3, b) specifically designed for the application.

The primary current path side of the circuit breaker is considered the rear of the circuit breaker, while the side with the cover containing the various indicators and manual operators is considered the front of the circuit breaker. By removing the front cover, the operating mechanisms of the circuit breaker are exposed. The stored energy mechanism assembly provides motion to each of the vacuum interrupters, moving contact assemblies through operating pushrods (Figure 3, w). In the same metal enclosed compartment as the stored energy mechanism is the circuit breaker racking mechanism and interlocks which control the movement of the circuit breaker between the test/disconnected and connected positions. The racking mechanism provides the motion to engage/disengage the primary disconnecting devices and to open/close the shutters in metal-clad switchgear.

B. THE STORED ENERGY MECHANISM

1) Mechanical Description

The stored energy mechanism is located in the front of the circuit breaker behind the front cover. The front cover is held in place by ten (10) cover bolts that may be removed, allowing access to the stored energy mechanism and its interlocks, auxiliary switches, racking mechanism, and other control devices.



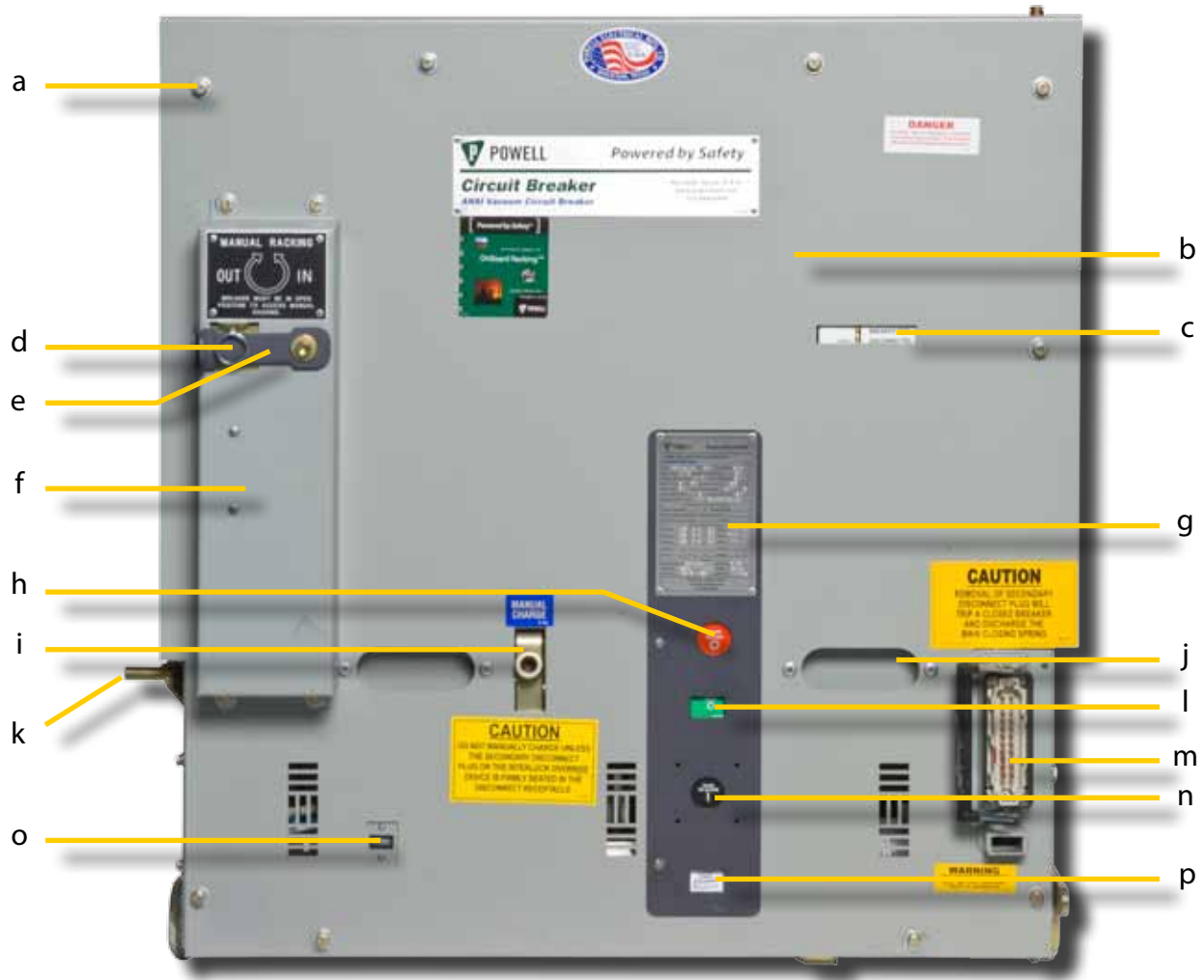
CAUTION

Prior to removing the front cover, ensure the circuit breaker is in the OPEN position and the main closing spring is fully discharged. Failure to do so may result in injury.

On the escutcheon of the stored energy mechanism, there are two (2) indicators that show the various states of operation of the mechanism and two (2) manual operators that will open/close the stored energy mechanism. The circuit breaker nameplate (Figure 1, g) is also located on the mechanism escutcheon. If for any reason the escutcheon is removed from the circuit breaker, it shall be verified that the serial number contained on the nameplate matches the engraved serial number plate (Figure 3, o) permanently affixed to the rear of the circuit breaker frame prior to installing the escutcheon.

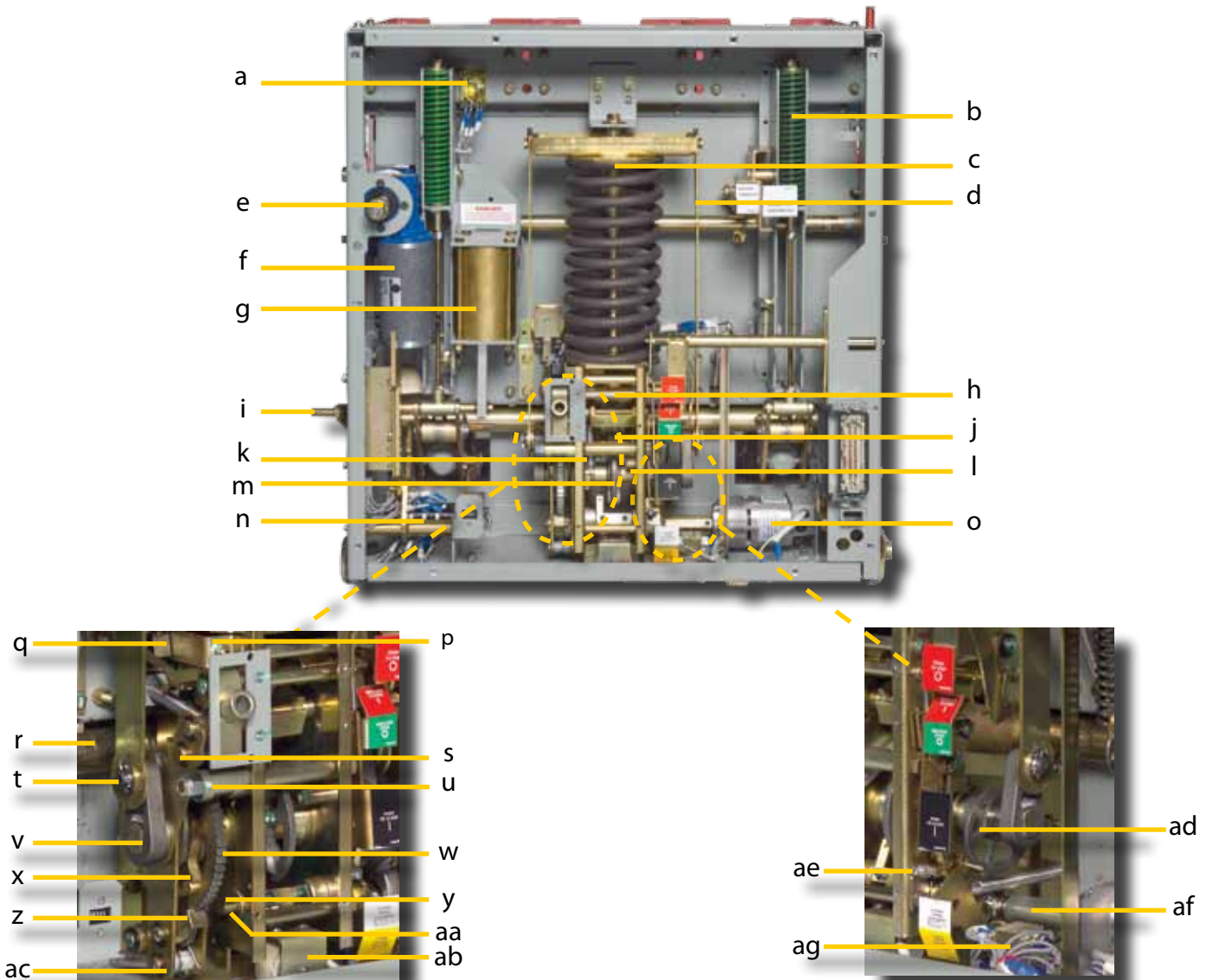


Figure 1 PowlVac® ARM Vacuum Circuit Breaker Front View with Cover



- | | |
|--|---|
| <ul style="list-style-type: none"> a. Cover Bolts b. Front Cover c. Breaker Position Indicator d. Emergency Racking Drive Shaft Shutter e. Padlock Provision - Movable Arm f. Interlock Window Assembly g. Nameplate h. Manual Trip Operator | <ul style="list-style-type: none"> i. Manual Charging Crank j. Handle k. MOC Actuator l. Circuit Breaker Open/Closed Indicator m. Secondary Disconnect Receptacle n. Manual Close Operator o. Operations Counter p. Spring Charge Indicator |
|--|---|

Figure 2 PowlVac® ARM Vacuum Circuit Breaker with Front Cover Removed



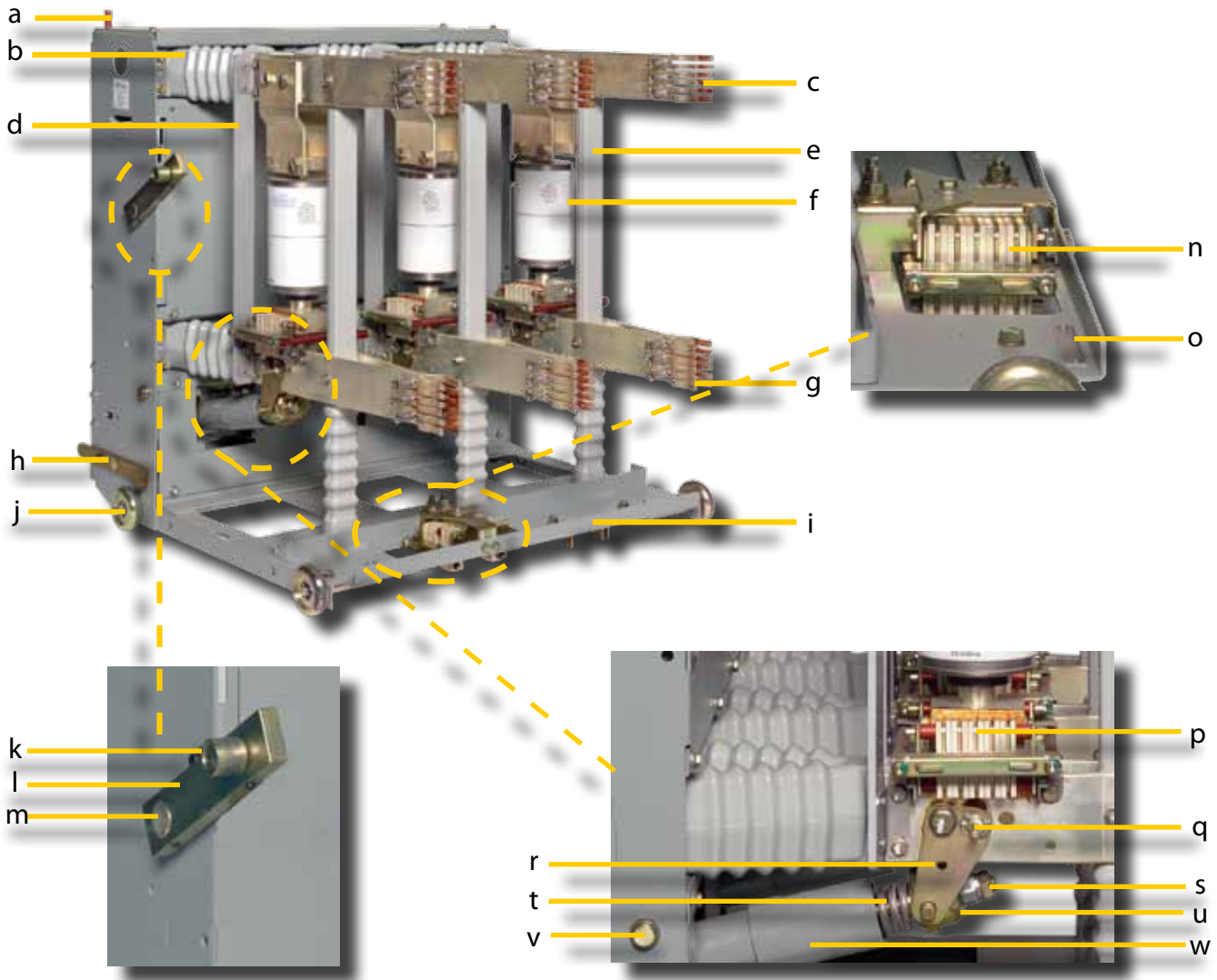
- a. Anti-Pump Relay
- b. Opening Spring
- c. Main Closing Spring
- d. Connecting Rod
- e. Emergency Racking Drive Shaft
- f. Racking Motor
- g. Shock Absorber (Dashpot)
- h. Secondary Trip Prop
- i. MOC Actuator
- j. Main Cam Roller
- k. Reset Spring

- l. Camshaft
- m. Main Closing Cam
- n. Auxiliary Switch
- o. Charging Motor
- p. Secondary Trip Prop Adjusting Screw
- q. Latch Check Switch
- r. Jackshaft
- s. Holding Pawl Support Arm
- t. Crank Pin
- u. Holding Pawl Adjusting Eccentric

- v. Crank Arm
- w. Ratchet Wheel
- x. Pawl Lift Drive Plate
- y. Close Latch Arm
- z. Drive Pawl
- aa. Close Latch Shaft
- ab. Closing Coil
- ac. Pawl Support Arm
- ad. Motor Cutoff Cam
- ae. Close Bar Adjusting Screw
- af. Charging Motor Drive Shaft
- ag. Motor Cutoff Switch



Figure 3 PowlVac® ARM Vacuum Circuit Breaker Rear View Without Barriers



- a. TOC Actuator
- b. Main Insulator (Wishbone)
- c. Upper Primary Disconnecting Device
- d. Support Strut
- e. Insulating Pole Support
- f. Vacuum Interrupter
- g. Lower Primary Disconnecting Device
- h. Anti-Rollout Latch
- i. Frame
- j. Wheel
- k. Crank Arm Roller
- l. Racking Crank Arm

- m. Racking Shaft
- n. Ground Connection
- o. Serial Number Plate
- p. Sliding Contact Finger Assembly
- q. Operating Pin
- r. Bell Crank
- s. Lock Nut
- t. Contact Loading Spring
- u. Spring Yoke
- v. Jackshaft Pin
- w. Operating Pushrod

The mechanism employed in the circuit breaker is a stored energy system which uses a charging motor to compress the main closing spring. During the closing operation the energy stored in the main closing spring is released. This allows the mechanism to close the vacuum interrupter contacts, compress the contact loading springs, charge the opening springs, and overcome frictional forces. When the circuit breaker is opened, the energy stored in the opening and contact loading springs is released, and the vacuum interrupter contacts are opened.

The charging motor (figure 2, o), located on the bottom right of the base pan, is assembled to the circuit breaker by a bracket that is bolted to the base pan. The charging motor drive shaft inserts into the eccentric drive shaft. The eccentric drive shaft is supported by needle roller bearings in the mechanism frame side sheets and transmits the motor torque to the left side of the mechanism.

When the charging motor is energized, the eccentric drive shaft rotates and causes the pawl support arms to pivot about the camshaft (Figure 2, l). The drive pawl, which is supported by the arms, engages with the ratchet wheel and drives the ratchet wheel one tooth at a time. To prevent backwards motion of the ratchet, a spring-loaded holding pawl is used to latch the ratchet wheel after each advance from the drive pawl.

To ensure correct synchronization of the drive and holding pawl, the position of the holding pawl support arms are adjustable by the holding pawl adjusting eccentric (Figure 2, u) located to the left front of

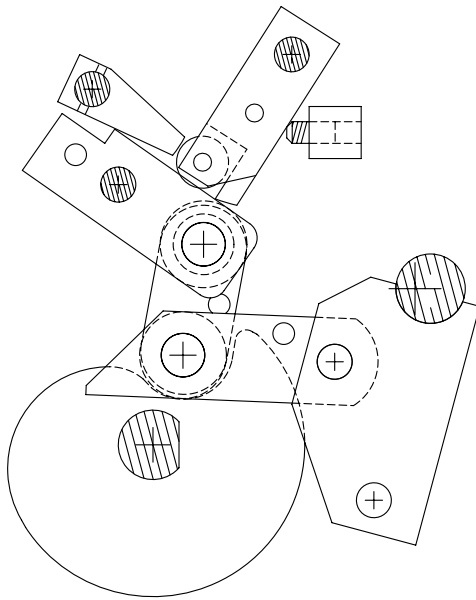
the mechanism. When the mechanism is operated manually, the top pawl becomes the drive pawl and the bottom pawl becomes the holding pawl.

The ratchet wheel (Figure 2, w) has projections from its side faces which engage the drive plates as it rotates. These drive plates are attached to the camshaft, thus causing the camshaft to rotate. Attached to the ends of the camshaft are crank arms (Figure 2, v). The crank pins (Figure 2, t) on the crank arms point outward. The crank arms engage the bottom ends of the connecting rods (Figure 2, d). The pins that project from the spring yoke, which straddles the main closing spring, engage the top ends of the connecting rods. As the camshaft rotates the connecting rods will pull the spring yoke downward, compressing the main closing spring.

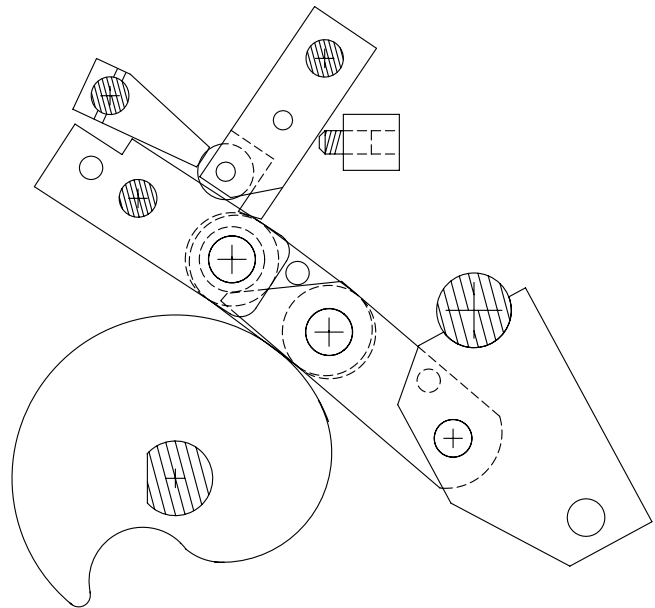
The ratchet wheel drives the camshaft so that the connecting rods go down to their lowest position, and then start to move upward. At a certain point, the spring force will overcome friction and resistance and start to rotate the camshaft. At the same time, the pawls are uncoupled from the ratchet wheel by the pawl lift drive plate (Figure 2, x) and the motor cutoff switch is operated. The motor cutoff switch (Figure 2, ag), located to the right of the mechanism, is operated by the spring charge indicator and motor cutoff cam (Figure 2, ad). The spring charge indicator (Figure 1, p) will display that the mechanism is charged. The camshaft would continue to rotate, except that it is restrained by the close latch arm (Figure 2, y) engaging against the close latch shaft (Figure 2, aa). The main closing cam, located between the mechanism side sheets, is now in a position where the fundamental linkage can move to the reset position.



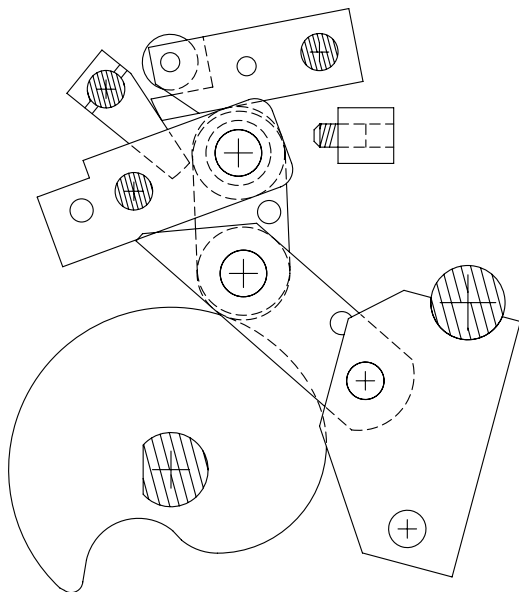
Figure 4 *Cam and Fundamental Linkage Positions*



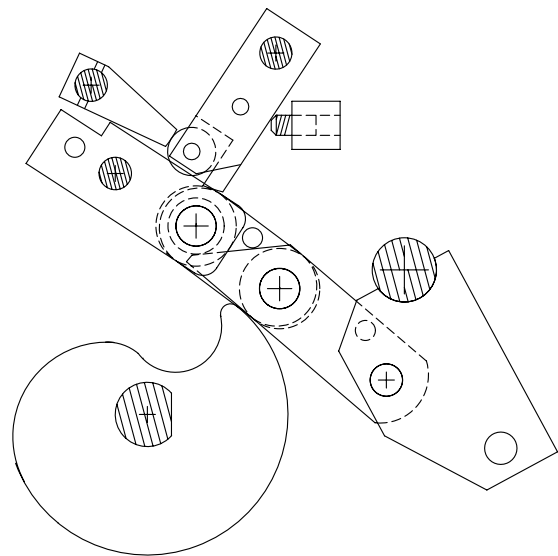
a) Breaker Open - Spring Charged - Links Reset



b) Breaker Closed - Spring Discharged

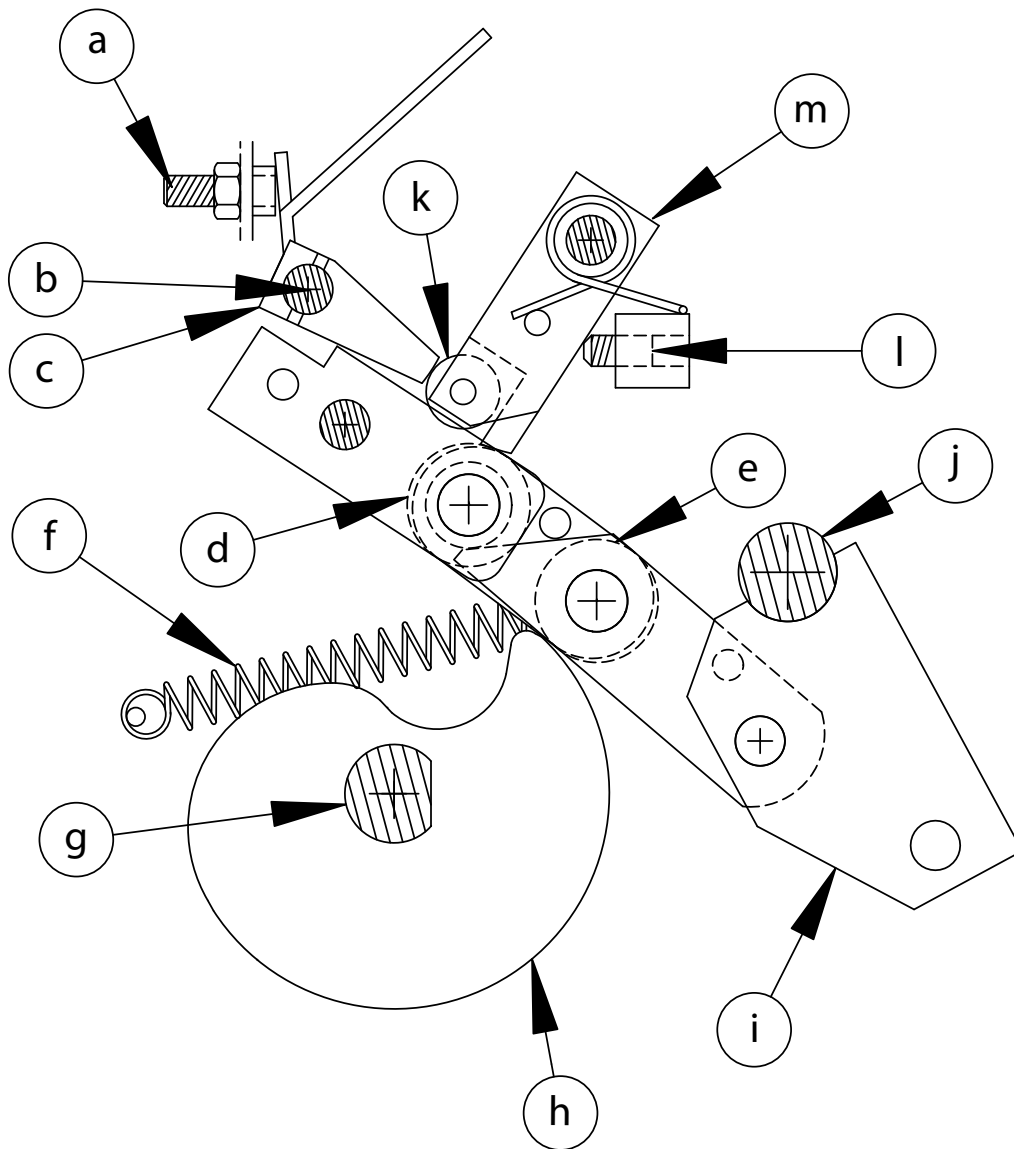


c) Breaker Open - Spring Discharged



d) Breaker Closed - Spring Charged

Figure 5 Mechanism and Trip Linkages



- a. Secondary Trip Prop Adjusting Screw
- b. Secondary Trip Prop Shaft
- c. Secondary Trip Prop
- d. Secondary Linkage Roller
- e. Main Cam Roller
- f. Reset Spring
- g. Camshaft
- h. Main Closing Cam
- i. Center Phase Operating Lever
- j. Jackshaft
- k. Primary Trip Prop Roller
- l. Primary Trip Prop Adjusting Screw
- m. Primary Trip Prop



The close latch, when released either by the closing coil or the manual close operator, allows the main closing spring to pull the crank arms upward thus rotating the main closing cam and driving the fundamental linkage into the closed position. This causes the main linkage to rotate the jackshaft such that the operating pushrods (Figure 3, w) are driven toward the current carrying side of the circuit breaker.

Each operating pushrod assembly has a recess at each end which encloses a contact loading spring (Figure 3, t). At the end of this spring is a spring yoke (Figure 3, u), which connects with bell cranks. The spring yoke is restrained by a lock nut on a stud which passes through the contact loading spring and is attached to the operating pushrod assembly. The contact loading spring has initial compression such that as soon as the vacuum interrupter contacts touch, the springs are preloaded to a value sufficient to resist vacuum interrupter contact separation under the highest electromagnetic forces exerted by the rated short circuit current. Further movement of the operating pushrod assembly compresses the contact loading spring even more and produces a gap between the face of the spring yoke and the lock nut. This "nut gap" is used to evaluate the erosion of the vacuum interrupter contacts.

For each phase, bellcranks (Figure 3, r) are located on the outside of the lower primary disconnecting devices (Figure 3, g) and are supported by bearings. Each bell crank is connected to an operating pin, which passes through a slot in the lower primary disconnecting devices and engage an extension to the vacuum interrupter assembly thus moving the vacuum interrupter contact. The bell cranks give an approximate 3 to 1 multiplication

of the contact loading spring force, enabling a lower spring rate to be used. It also multiplies the contact movement by a factor of approximately 3, so that the mechanism linkages have relatively large movements and are less critical.

In the cam and fundamental linkage positions (Figure 4, b & d), the contact loading springs and the main opening springs are both acting to compress the three (3) main mechanism links. The jackshaft extends from the left to the right side of the circuit breaker frame and is supported at the main circuit breaker frame side sheets and by the mechanism side sheets. The outer operating levers on the jackshaft have connections to the circuit breaker opening springs (Figure 2, b).

The fundamental linkage is restrained from movement by the secondary trip prop acting on the primary trip prop roller. A component of force tends to make the primary trip prop rotate upward, but it is restrained by the secondary trip prop face acting on the primary trip prop roller. The clearance between the primary trip prop roller and the secondary trip prop is controlled by the primary trip prop adjusting screw. When the trip shaft is rotated by the action of the manual trip operator or the primary shunt trip coil, the secondary trip prop face moves downward and permits the primary trip prop to rotate upward, thus permitting the main linkage to move upward and the jackshaft to rotate, opening the circuit breaker. The left jackshaft levers engage a shock absorber (Figure 2, g), which controls the rebound of the vacuum interrupter contacts on an opening operation. An extension of the jackshaft projects through the left circuit breaker side sheet and operates the MOC actuator (Figure 2, i).

Figure 6 Operation Sequence

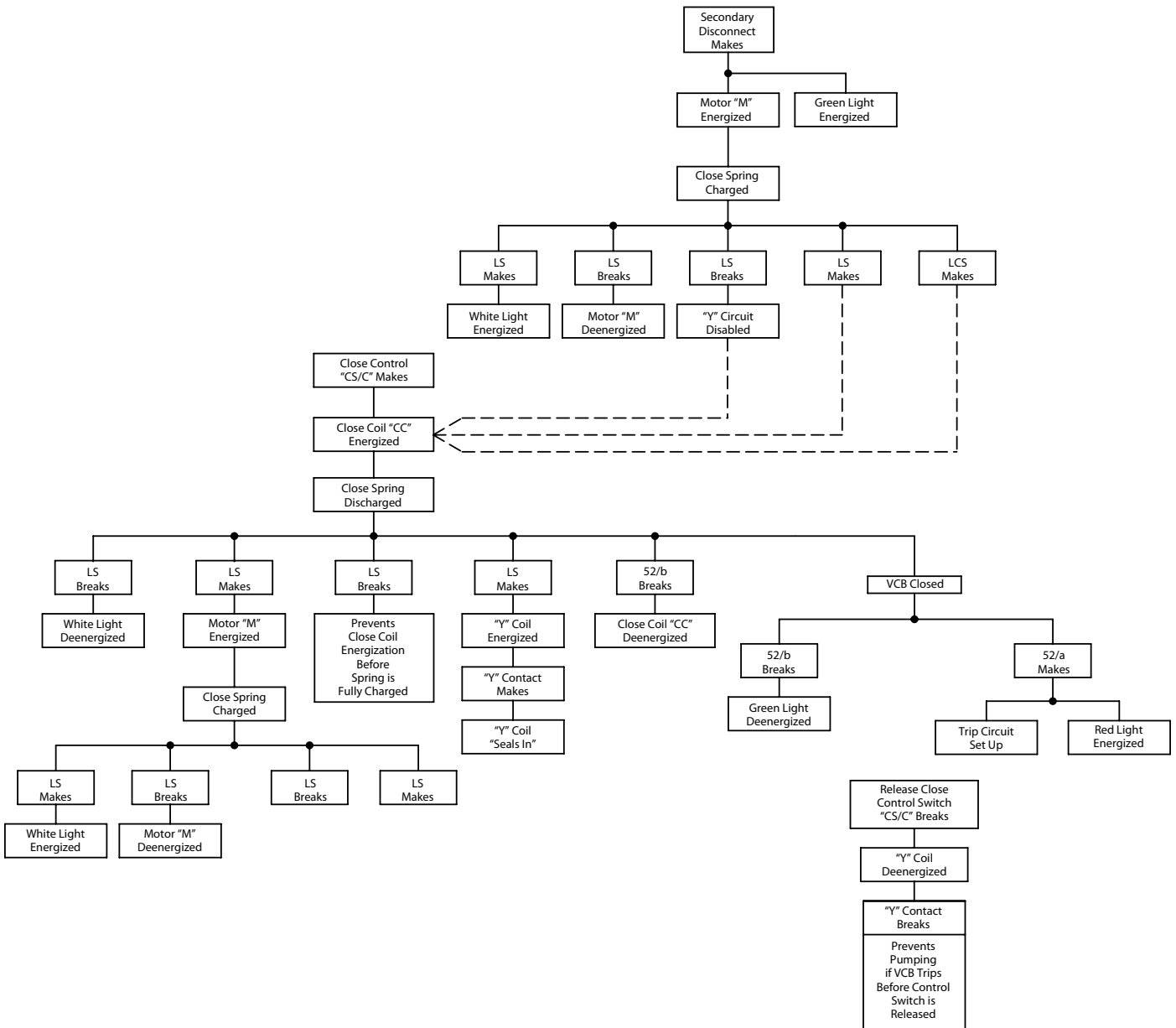
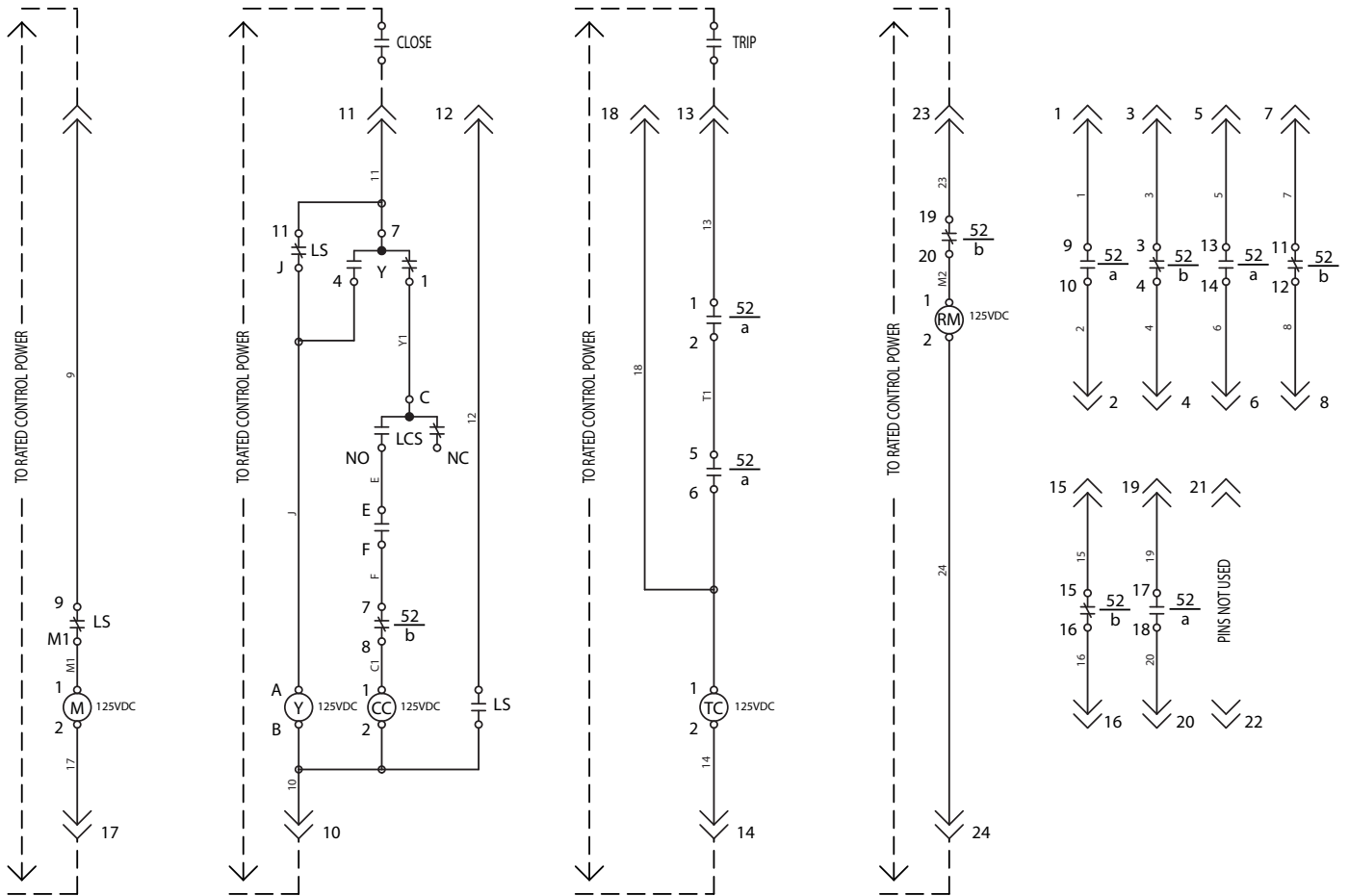




Figure 7 Typical AC/DC Control Scheme



LEGEND

- LS -- Spring Charge Limit Switch (Shown with Spring Discharged)
- LCS -- Latch Check Switch (Shown with Spring Discharged)
- Y -- Anti-Pump Relay
- TC -- Breaker Trip Coil
- CC -- Breaker Close Coil
- M -- Charging Motor
- $\frac{52}{a}$ -- Breaker Auxiliary Contact (Normally Open)
- $\frac{52}{b}$ -- Breaker Auxiliary Contact (Normally Closed)
- SD -- Breaker Secondary Disconnect
- NO -- Normally Open
- NC -- Normally Closed
- C -- Common
- RM -- Racking Motor
- TB -- Terminal Block

With the standard electrical control scheme, as soon as the main closing spring is discharged on a closing operation, the charging motor is switched on to recharge the springs. This leaves the main closing cam in a position where a tripped linkage can reset under the action of the reset spring (Figure 2, k) and the primary and secondary trip props can fall into the reset position. The reset spring stretches between an extension of the main cam roller pin and a spring support pin located on the left mechanism side sheet. The latch check switch (Figure 2, q), operated by a lever on the trip shaft, will close as the secondary trip prop reaches the fully reset position.

2) *Electrical Description*

a. **Charging Motor**

The function of the charging motor (Figure 2, o) is to compress the main closing spring of the stored energy mechanism, thus providing the necessary energy to close the circuit breaker. The charging motor, located at the bottom right of the base pan, is assembled to the circuit breaker by a bracket that is bolted to the base pan.

b. **Motor Cutoff Switch**

The motor cutoff switch (Figure 2, ag) provides an electrical break in the control circuit supplying the charging motor when the main closing spring is fully charged and the stored energy mechanism is ready for a closing operation. It is located at the bottom right of the mechanism, and is supported by a bracket which is bolted to the circuit breaker base pan.

c. **Anti-Pump Relay**

The anti-pump relay (Figure 2, a) provides a logic function for the control circuit which prevents a continuous electrical close signal from causing the circuit breaker to continuously re-close after a trip signal. The anti-pump relay is located on the circuit breaker frame, inside the circuit breaker to the right of the left opening spring and is supported by two screws.

d. **Operating Solenoids**

Electrical operation of the circuit breaker is accomplished using operating solenoids.

The closing coil (Figure 2, ab) is an operating solenoid that is located at the bottom center of the mechanism, and is assembled to the circuit breaker base pan by bolts accessible from underneath the circuit breaker.

The primary shunt trip coil is located at the top left side of the mechanism, and is assembled to the lower frame channel by two bolts.

Either a secondary trip coil or an undervoltage device may be furnished as an option. When furnished, either of these devices will be located at the top right side of the mechanism, installed on the lower frame channel. Only one of these two operating solenoids may be furnished on any one circuit breaker, as both devices are located in the same space.



e. Control Circuit

The typical AC and DC electrical control schemes are shown in Figure 7. The control scheme of any particular circuit breaker may differ from these typical schemes depending on the user's requirements, operating solenoids, and the control devices furnished with that circuit breaker.

The sequence of operation for all control schemes is shown in Figure 6. Circuit breaker mounted auxiliary contacts not used in the control circuit are brought out for control and indication functions. The metal-clad switchgear equipment may provide a circuit breaker MOC (Mechanism Operated Cell Switch) for additional contacts.

C. AUTOMATIC RACKING MECHANISM

1) General Description

The racking mechanism is the mechanical assembly that facilitates moving the circuit breaker between the breaker test/disconnected and the connected positions in the circuit breaker compartment. The main racking mechanism components for the PowlVac[®] Automatic Racking Mechanism (ARM) are shown and described in the following sections:

a. Breaker Position Indicator

The breaker position indicator (Figure 1, c) is visible through an opening in the circuit breaker front cover. The indicator displays whether the circuit breaker is in the connected or the test/disconnected positions. When the breaker position indicator displays

“BREAKER CONNECTED”, and this is fully visible in the aperture, the circuit breaker is in the connected position. When the breaker position indicator displays **“BREAKER TEST/DISCONNECTED”**, and this is fully visible in the aperture, the circuit breaker is in the test/disconnected position. In positions other than the connected and test/disconnected positions, the breaker position indicator does not display an indication. Refer to **Ch 4 Installation, E. INSERTING THE CIRCUIT BREAKER INTO THE METAL-CLAD SWITCHGEAR** for more information.

b. Interlocking

PowlVac circuit breakers are provided with several interlocks that operate in conjunction with the circuit breaker compartment to ensure the proper operation of the circuit breaker. Do not attempt to modify or bypass these interlocks, as they are necessary for the safe operation of the circuit breaker.

The purpose of the interlocks is to ensure:

- The circuit breaker cannot be moved from the test/disconnected to the connected position unless the main circuit breaker contacts are opened and the secondary control circuitry from the compartment to the circuit breaker is completed, and the circuit breaker cannot be removed from the connected to the test/disconnected position unless the main contacts are opened.
- The control circuits cannot be broken when the circuit breaker is in the connected position.

- The circuit breaker cannot be removed from the circuit breaker compartment with the circuit breaker closed or with the main closing spring charged.

The ARM circuit breaker interlocking is primarily achieved by means of an interlock bar attached to the secondary disconnect receptacle and tripping linkage and roller. This is located under the frame of the circuit breaker behind the racking shaft drive shutter, attached to the positive interlock that interfaces with the circuit breaker compartment.

The tripping linkage and roller under the breaker frame follow a cam mounted in the circuit breaker compartment. The cam, in all intermediate positions between the test/disconnected and connected position lifts the tripping roller. Lifting the tripping roller actuates the manual trip operator which holds the breaker in a trip free condition. The manual trip operator also actuates the latch check switch, thus blocking any electrical closing signal.

The interlock bar attached to the secondary disconnect prevents the circuit breaker from being moved from the test to connected position without the secondary disconnect installed.

c. Positive Interlock

Moving the emergency racking drive shaft shutter downward prevents the closing of the circuit breaker by operating a linkage which blocks the mechanism. If the breaker is not in the open position, the shutter cannot be opened enough to insert the racking

handle. This interlock ensures that the circuit breaker is open when it is manually racked into the compartment. Once the circuit breaker reaches the operating position and the shutter mechanism is released, the circuit breaker can now be closed. When the circuit breaker is in the closed position, the shutter is no longer free to move. This blocks the operation of the emergency racking drive shaft, deterring any attempt to remove a closed circuit breaker from the compartment.

2) Racking Mechanism

The racking mechanism consists of a racking shaft (Figure 3, m) with racking crank arms (Figure 3, l) at each end which are supported by the frame side sheets. The racking shaft also supports a motor assembly (Figure 3, n) at the left end just inside the right side sheet. In addition, the racking crank arms have rollers attached to each end of the racking shaft which engage the vertical slots of the racking cams in the circuit breaker compartment. Rotation of the racking crank arms will drive the circuit breaker into or out of the connected position. This action also operates the compartment shutters.

Bolts on the left and right side sheets provide a positive stop to the left crank arm. This positive stop prevents further rotation of the racking shaft, thus stopping circuit breaker travel. At this time, the breaker position indicator on the front of the circuit breaker will display **"BREAKER CONNECTED"**.



D. CIRCUIT BREAKER COMPARTMENT INTERFACES

1) Primary Disconnecting Devices

There are six primary disconnecting devices on the circuit breaker. They are arranged, two per phase, with the upper device connected to the stationary end of the vacuum interrupter, and the lower device connected to the moving end of the vacuum interrupter assembly. Each primary disconnecting device (Figure 3, c & g) has multiple contact fingers which will mate with the stationary primary disconnecting devices in the circuit breaker compartment.



CAUTION

Do not handle or move the circuit breaker by the primary disconnecting devices, as damage may occur.

2) Secondary Disconnecting Devices

Control power is transferred from the metal-clad switchgear to the circuit breaker by means of the secondary disconnect device. The secondary disconnect receptacle (Figure 1, m) is located on the bottom right side of the circuit breaker. The secondary disconnect plug is attached to the switchgear and is located on the right side wall of the circuit breaker compartment. This arrangement allows the secondary connection to be visible in all positions of the circuit breaker.

3) MOC (Mechanism Operated Cell Switch) Actuator

The MOC, located in the switchgear, is operated by a lever which extends from the circuit breaker operating mechanism. Movement of the MOC actuator (Figure 2, i) is directly related to the movement of the circuit breaker mechanism and contacts.

4) TOC (Truck Operated Cell Switch) Actuator

The TOC, located in the switchgear, is operated by circuit breaker truck position. To accomplish this, a TOC actuator (Figure 3, a) is located on the right top of the circuit breaker frame and it is designed to strike the TOC as the circuit breaker travels to the connected position.

5) Ground Connection

The ground connection is an assembly of spring-loaded fingers that effectively grounds the circuit breaker frame as it is inserted into the circuit breaker compartment. The ground connection (Figure 3, n) is located at the rear edge of the floor pan of the circuit breaker between the center and right poles of the circuit breaker. An extension of the metal-clad switchgear ground bus is secured to the circuit breaker compartment floor and engages the ground connection as the circuit breaker is placed into the disconnected position. The ground connection system remains engaged in all subsequent positions of the circuit breaker until the circuit breaker is removed from the compartment.

6) *Shutter Rollers*

The circuit breaker travels between the test/disconnected and connected positions as the crank arm rollers (Figure 3, k) engage the vertical slots of the racking cams attached in the circuit breaker compartment. This action also drives the compartment shutters to open/close which allows the primary disconnecting devices to connect/disconnect. Downward movement of the crank arms rollers in the slots will move the shutters to the fully open position before the circuit breaker travels towards the connected position.

7) *Anti-Rollout Latch*

The circuit breaker is equipped with an anti-rollout latch (Figure 3, h) which prevents inadvertent removal from the circuit breaker compartment by engaging a block in the circuit breaker compartment.

E. VACUUM INTERRUPTERS

PowlVac® circuit breakers utilize sealed vacuum interrupters to control the primary circuit. Some vacuum interrupters appear to be identical in size and shape externally, but types vary in rating due to the differences in their internal construction. Refer to *Table E, Primary Current Path* for a listing of vacuum interrupters used in PowlVac ARM circuit breakers.

F. VACUUM INTERRUPTER CONNECTION

Connection to the vacuum interrupter stems are made by means of copper contact blocks. The top stem of the vacuum interrupter is threaded and a copper contact block is screwed onto the stem. The contact block and the vertical connector bars are bolted together and the vertical connector bars in turn are assembled to the upper primary disconnecting devices of the circuit breaker. Another copper contact block is mounted to the bottom or moving stem of the vacuum interrupter. The sliding contact finger assembly (Figure 3, p) makes contact with this block and the lower primary disconnecting devices. The multiple parallel paths of the sliding contact finger assembly keeps the current density low.



Ch 4 Installation

Figure 8 Circuit Breaker with Shipping Bracket

A. RECEIVING

When the circuit breaker is received check for any sign of damage. If damage is found or suspected, file all claims immediately with the transportation company and notify the nearest Powell representative.

Estimated size and weight for shipping a PowlVac® STD vacuum circuit breaker on a pallet:

- Size: 42" width x 42" depth x 47" height
- Approximate Weight: 675 lbs.

Figure 10 shows the circuit breaker enclosed in the carton used for shipment. The carton is attached to the shipping pallet by two metal bands. Remove these bands and lift the carton from the pallet so that the circuit breaker is visible. The circuit breaker is attached to the pallet by three metal shipping brackets. When these are removed the circuit breaker may be removed from the shipping pallet. Refer to **Ch 4 Installation, B. HANDLING**, for more information.

When a metal-clad switchgear assembly is installed in a Power Control Room, a circuit breaker housed in the lower circuit breaker compartment may be shipped installed in the equipment. In these cases, the circuit breaker will be in the test/disconnected position and it will be bolted to the compartment floor by use of a shipping bracket (Figure 8, a). The horizontal leg of the bracket is bolted to the compartment floor and the vertical leg is bolted to the front of the circuit breaker using the lower cover bolts. Remove these four bolts, discard the shipping angle, and replace the four bolts.



a. Shipping Bracket

Note: PowlVac® STD circuit breaker shown.

B. HANDLING

After the circuit breaker has been removed from its shipping pallet it may be rolled on its own wheels on a level surface. This is the preferred way of handling the circuit breaker. When rolling the circuit breaker it should be pushed and steered by the steel frame or the front cover.

CAUTION

Do not handle or move the circuit breaker by the primary disconnecting devices, as damage may occur.

If necessary, the circuit breaker can be moved by a fork lift truck or an overhead crane. When using a fork lift truck take care to avoid components located under the circuit breaker floor pan. The forks on the truck should be set for a dimension over the forks of 28 inches. The forks should then ride under the wheel axles. The circuit breaker can also be lifted by an overhead crane using the two lifting points which have been provided for hooks at the top of the circuit breaker frame side sheets (Figure 9).

Figure 9 Circuit Breaker on Crane



C. STORAGE

It is recommended that the circuit breaker be placed into service immediately in its permanent location after completing the commissioning tests. If this is not possible, the following precautions must be taken to ensure the proper storage of the circuit breaker:

1. Since moisture has an adverse effect on the insulating parts, the circuit breaker should be carefully protected against condensation, preferably by storing it in a warm dry room of moderate temperature, such as 40°-100°F. Circuit breakers used in outdoor metal-clad switchgear should be stored in the equipment only when power is available and the anti-condensation heaters are in operation.
2. The circuit breaker should be stored in a clean location free from corrosive gases or fumes. Particular care should be taken to protect the equipment from moisture and cement dust, as this combination has a corrosive effect on many parts.

Figure 10 Circuit Breaker in Shipping Carton





3. Unplated surfaces of the operating mechanism, such as, rollers and latches, should be coated with grease/oil to prevent rusting.

If the circuit breaker is stored for any length of time, it should be inspected periodically to see that rusting has not started and to ensure good mechanical condition. If the circuit breaker is stored under unfavorable atmospheric conditions, it should be cleaned and dried before being placed into service.

D. PLACING THE CIRCUIT BREAKER INTO SERVICE

Before shipment from the factory, all circuit breaker functions are thoroughly checked. The user must verify functions after receipt. Powell recommends that the tests be performed in the sequence listed below:

- 1) *High Voltage Insulation Integrity*


CAUTION

High voltages across the open gaps of the vacuum interrupter can produce radiation. Personnel should stand at least one meter away from the circuit breaker with the covers in place when conducting high voltage test. Test voltages should not exceed 15kVAC (27kV DC) for circuit breaker with a rated maximum voltage of 4.76kV, and 27kVAC (50kV DC) for circuit breaker with a rated maximum voltage of 15kV.

The primary circuit insulation on the circuit breaker may be checked phase-to-phase and phase-to-ground using a 2500V insulation resistance tester. Since definite limits cannot be given for satisfactory insulation values when testing with an insulation resistance tester, a record should

be kept of the insulation resistance tester readings as well as the temperature and humidity readings. This record should be used to detect any weakening of the insulation system from one check period to the next.

To check insulation integrity, the AC high potential test described below is strongly recommended. DC testing is not the preferred method, however, values are provided due to the availability of DC test sets.


CAUTION

If DC high potential testing is performed, the DC high potential test machine must not produce instantaneous peak voltages exceeding 50kV.

The circuit breaker insulation should be tested with the circuit breaker vacuum interrupter contacts in the closed position.

Test each pole of the circuit breaker separately, with the other 2 poles and the frame grounded. Perform the field dielectric test described in ANSI Standard C37.20.2, at the voltage level appropriate for the equipment.

Table A Field Dielectric Test Values	
Rated Maximum Voltage (kV rms)	Power Frequency Withstand (kV rms)
4.76	15
8.25	27
15.0	27

This test will have checked all of the primary phase-to-ground and phase-to-phase insulation.

**CAUTION**

After the high potential is removed, an electrical charge may be retained by the vacuum interrupters. Failure to discharge this residual electrostatic charge could result in an electrical shock. All six primary disconnecting devices of the circuit breaker and the metallic mid band ring if present should be grounded and remain grounded for at least one minute to reduce this electrical charge before coming in to contact with the primary circuit.

**CAUTION**

Remove all grounding conductors applied for this test before placing the circuit breaker back into service.

The tests described in this section are the only tests required to ascertain insulation integrity. Because of the design of the PowlVac® insulation system, no valid data can be obtained utilizing other types of high voltage insulation tests.

2) *Vacuum Integrity***CAUTION**

Applying abnormally high voltage across a pair of contacts in vacuum may produce x-radiation. The radiation may increase with increased voltage and/or decreased contact spacing.

X-radiation produced during this test with the voltage specified in Table A and normal contact spacing is extremely low and well below the maximum permitted by standards.

Do not apply voltage that is higher than the recommended value. Do not use contact separation that is less than the normal open position separation of the circuit breaker contacts.

Powell recommends AC testing for reliable verification of vacuum integrity. All PowlVac 5kV and 15kV circuit breakers shall be tested with a minimum of 25kVAC applied across fully open contacts for 10 seconds. No dielectric breakdown during the test period constitutes a successful test.

Note: *This test does not replace the AC high potential testing (Hipot) used to determine "High voltage insulation integrity." See **Ch. 4 Installation, D. PLACING THE CIRCUIT BREAKER INTO SERVICE, 1) High Voltage Insulation Integrity.***

Powell offers a compact and lightweight **PowlVac Vacuum Integrity Tester** designed specifically for PowlVac circuit breakers. If this device is used refer to the instruction bulletin provided with the vacuum integrity tester.



Powell recognizes the widespread use of DC hipot equipment in the field and the desire to use this equipment to verify vacuum integrity. However, the capacitive component of the vacuum interrupter during DC testing may yield false negative test results, which are often misinterpreted as vacuum interrupter failure. When DC testing is performed, a test set providing a full wave rectified 50kVDC hipot voltage can be applied for 5 seconds as a “go - no go” test.

Recording the leakage readings is not necessary, as a dielectric breakdown will trip all portable DC hipot test sets. If a DC test breakdown occurs, the test must be repeated after reversing the DC high voltage test supply connection across the vacuum interrupter. A vacuum interrupter should be questioned only if it has failed both tests.

No attempt should be made to try to compare the condition of one vacuum interrupter with another, nor to correlate the condition of any vacuum interrupter with low values of DC leakage current. There is no significant correlation.

 **CAUTION**

After the high potential is removed, an electrical charge may be retained by the vacuum interrupters. Failure to discharge this residual electrostatic charge could result in an electrical shock. All six primary disconnecting devices of the circuit breaker and the metallic mid band ring if present should be grounded and remain grounded for at least one minute to reduce this electrical charge before coming in to contact with the primary circuit.

 **CAUTION**

When testing with DC, use a DC high potential test (hipot) set with full wave rectification. Many DC high potential test sets use half-wave rectification. Do not use these half-wave rectifiers. The capacitance of the vacuum interrupter in combination with the leakage currents in the rectifiers and its DC voltage measuring equipment may result in applying peak voltages as much as three times the measured voltage. These abnormally high voltages may give a false indication of a defective vacuum interrupter, and may produce abnormal x-radiation.

3) *Control Voltage Insulation Integrity*

If the user wishes to check the insulation integrity of the control circuit, it may be done with a 500V or 1000V insulation resistance tester or with an AC high potential tester. The AC high potential test should be made at 1125V, 50 or 60 Hz for one minute. The charging motor must be disconnected prior to testing the control circuit. The charging motor itself may be similarly tested at a voltage not to exceed 675V, 50 or 60 Hz. Be sure to remove any test jumpers and reconnect the charging motor when the tests are complete.

 **CAUTION**

If DC high potential testing (hipot) is required, the DC high potential test machine must not produce instantaneous peak voltages exceeding 50kV.

 **CAUTION**

Remove all grounding conductors applied for this test before placing the circuit breaker back into service.

4) Mechanical Operation Check

CAUTION

Care must be exercised to keep personnel, tools, and other objects clear of mechanism which are to be operated or released.

The contacts of the vacuum interrupter during normal operation cannot be closed unless the secondary disconnect plug is inserted into the secondary disconnect receptacle. To check the circuit breaker outside of the circuit breaker compartment, it is necessary to simulate the connection of secondary disconnecting device by inserting the secondary disconnect override device (Figure 11) in the secondary disconnect receptacle. This device must be removed after testing and before the circuit breaker is inserted into the compartment. The mechanical operation of the circuit breaker is checked by inserting the manual charging handle into the manual charging crank and pushing down until a metallic click is heard. (This indicates that the holding pawl has dropped into place on the ratchet wheel). Lift the handle until it is horizontal and then depress. The procedure is repeated until the spring charge indicator indicates **"CLOSING SPRING CHARGED"**. This requires about 60 operations of the handle. Remove the handle.

Figure 11 Secondary Disconnect Override Device



Note: PowlVac® STD circuit breaker shown.

CAUTION

The MOC actuator is exposed when the circuit breaker is outside the metal-clad switchgear and can cause serious injury if the test personnel or any object is in the travel path during operation. Care should be taken to isolate the MOC side of the circuit breaker for these tests.

Push the manual close operator (Figure 1, n) inward and the circuit breaker will close. The circuit breaker open/closed indicator located above the manual close operator will now display **"BREAKER CLOSED"**. Push the manual trip operator (Figure 1, h) inward, which is located at the top of the escutcheon and the circuit breaker open/closed indicator will now display **"BREAKER OPEN"**.



5) *Electrical Operation Check*

To check the basic electrical operation of the circuit breaker, a circuit breaker test cabinet should be used. Connect the secondary disconnect from the test cabinet to the circuit breaker to be tested. The test cabinet provides control voltage via a secondary disconnect plug to the circuit breaker and the appropriate control switches to verify the close and open functions of the circuit breaker. Specialized versions of the test cabinet may also contain circuits for circuit breakers equipped with dual shunt trip coils, undervoltage devices, or other options. With the secondary disconnect plug installed in the circuit breaker under test, operate the power switch on the test cabinet. The charging motor will automatically charge the stored energy mechanism's main closing springs. Operation of the control switch on the front door of the test cabinet to the "close" position will cause the circuit breaker to close.

The circuitry is arranged to cause the charging motor to operate again and charge the main closing spring. Operating the control switch on the front door of the test cabinet to the "open" position will cause the circuit breaker to open.

Alternatively, a test jumper cable may be used to electrically operate the circuit breaker using the control circuitry of the circuit breaker compartment. Caution must be exercised if this option is chosen to ensure that operation of the control circuitry of the compartment used for test does not cause undesirable effects or unintended operation of other interconnected equipment such as supervisory controls, SCADA, or automatic transfer schemes.

First, remove the control fuses in the compartment. Connect the jumper cable to the secondary disconnect plug in the compartment and to the circuit breaker. Insert the fuses. The charging motor will automatically charge the stored energy mechanism's main closing springs. Operation of the breaker control switch on the front door of the compartment will cause the circuit breaker to close. The circuitry is arranged to cause the charging motor to operate again and charge the main closing spring. Operating the breaker control switch on the front door will cause the circuit breaker to open.

6) *Emergency Racking Mechanism Check*

The emergency racking mechanism may be checked outside the circuit breaker compartment.

The emergency racking drive shaft can be accessed by moving the emergency racking drive shaft shutter downward, .

Note: *The emergency racking drive shaft shutter cannot be moved downward unless the open circuit breaker is open.*

Insert the racking handle onto the racking drive shaft. The racking crank arms at the sides of the circuit breaker should be in the fully withdrawn position and point towards the primary disconnecting devices.

The breaker position indicator on the front of the circuit breaker should display, **“BREAKER TEST/DISCONNECTED”**. Rotate the racking handle in a counterclockwise direction. The racking crank arms will move downward and rotate until the breaker position indicator displays **“BREAKER CONNECTED”**. Stop bolts on the side sheet of the breaker prevent further rotation of the racking drive shaft. Once the breaker position indicator displays **“BREAKER CONNECTED”**, the racking mechanism will have reached the end of its travel and a significant increase in the amount of resistance encountered will indicate that further force should not be exerted. Once factory torque limits are reached a torque limiting clutch on the racking handle will engage and disallow any further racking. In this position, the racking handle may be removed from the racking drive shaft and the racking drive shaft shutter will spring back to the closed position.

Once again, depress the racking drive shaft shutter, insert the racking handle and rotate in a clockwise direction until the racking crank arms are once more in the fully withdrawn position and the breaker position indicator displays **“BREAKER TEST/ DISCONNECTED”**.

**CAUTION**

Pole unit parts are energized at full circuit voltage when the circuit breaker is in the connected position. Before moving the circuit breaker into the connected position, make sure the main barrier assembly has been properly fastened in place. Failure to do this may cause serious damage or injury.

E. INSERTING THE CIRCUIT BREAKER INTO THE CIRCUIT BREAKER COMPARTMENT

Refer to the metal-clad switchgear instruction bulletin and drawings produced specifically for the installed equipment for additional information and cautions before attempting to insert the circuit breaker into the metal-clad switchgear equipment.

**IMPORTANT**

Be sure that the racking crank arms at the sides of the circuit breaker point in the direction of the primary disconnecting devices and the circuit breaker position indicator displays breaker test/disconnected.

Each circuit breaker and circuit breaker compartment is provided with interference plates which are designed to ensure that no circuit breaker with less than the required voltage, continuous current, or interrupting current rating is placed in the incorrect circuit breaker compartment. If you attempt to insert an improperly rated circuit breaker into the circuit breaker compartment, these plates will interfere with each other and deter further insertion. The interference will occur before the circuit breaker reaches the disconnected position. Do not attempt to force the circuit breaker past the compartment interference plate or remove the interference plates from either the compartment or the circuit breaker. Remove the incorrect rated circuit breaker and insert a properly rated circuit breaker into the circuit breaker compartment.



1) *Prior to Inserting the Circuit Breaker into the Circuit Breaker Compartment*

a. **Check the Primary Disconnecting Devices and Circuit Breaker Compartment**

Examine the primary disconnecting devices for any signs of damage and contamination. Check to see that none are bent out of alignment. If contamination is found refer to **Ch 5 Maintenance B. MECHANISM AREA, 2) Lubrication** for cleaning and lubrication procedures. If the primary disconnecting devices are damaged make no attempt to repair. Contact Powell for further information.


Examine the circuit breaker compartment to see that it is clean and clear of debris that might interfere with circuit breaker travel.

b. **Racking the Circuit Breaker Into the Circuit Breaker Compartment**


The described racking procedures apply only for the PowlVac® ARM circuit breaker. For all other constructions, refer to the appropriate instructions or instruction bulletin(s) for the applicable racking procedures.

The circuit breaker is designed to be electrically racked into the circuit breaker compartment from a remote location with the compartment door closed. The ARM circuit breaker may also be manually racked using the emergency override option with the compartment door open.


Note: *The described racking procedures are for racking the circuit breaker into the lower circuit breaker compartment only. To rack the circuit breaker into an upper circuit breaker compartment, refer to the metal-clad switchgear instruction bulletin for detailed information.*

 **CAUTION**

Before inserting any circuit breaker into a compartment, the user must verify that the circuit breaker rating meets or exceeds the metal-clad switchgear rating.

 **CAUTION**

Before inserting a circuit breaker into the circuit breaker compartment, be sure that the indicator flag on the front cover of the circuit breaker displays "BREAKER TEST/DISCONNECTED".

 **CAUTION**

Before attempting to rack a circuit breaker in or out of a circuit breaker compartment equipped with a key interlock, make sure that the interlock is unlocked and in the open position.



IMPORTANT

The illustrations shown for all racking procedures are provided to show device locations and are intended only as a guideline. These illustrations may not be representative of site specific safety practices for performing the procedure. Before attempting any racking procedure, review Chapter 2.

2) *Inserting the Circuit Breaker to the Test/Disconnected Position*



CAUTION

Prior to inserting the circuit breaker into the circuit breaker compartment, make sure that the control circuits are deenergized.

- a. Verify that the circuit breaker open/closed indicator displays “**BREAKER OPEN**” and if not, press the manual trip operator to open the circuit breaker.
- b. To insert the circuit breaker into the lower circuit breaker compartment, open the compartment door and align the wheels with the floor pan channels of the compartment. Verify that the floor pan channels are free of debris prior to inserting the circuit breaker.
- c. Roll the circuit breaker into the compartment until the first anti-rollout latch, located on the right side of the circuit breaker catches the compartment latch.

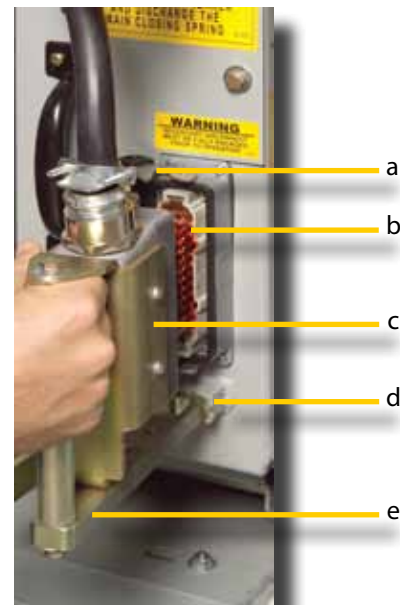
Note: *This is the Disconnected Position.*

- d. Insert the circuit breaker compartment’s secondary disconnect plug (Figure 12, c) into the circuit breaker secondary disconnect receptacle (Figure 12, b). Once the plug is fully inserted, move the secondary disconnect latch, from left to right until it has engaged the housing of the secondary disconnect plug.

Note: *This is the Test Position.*

- e. Roll the circuit breaker in the compartment until the racking crank arms contact with the vertical slots in the compartment. The second anti-rollout latch on the lower right side of the circuit breaker will engage the block in the compartment, preventing accidental removal of the circuit breaker from the compartment.

Figure 12 Secondary Disconnecting Device



- a. Secondary Disconnect Latch
- b. Secondary Disconnect Receptacle
- c. Secondary Disconnect Plug
- d. Secondary Disconnect Guide Sleeve
- e. Interlock Bar

Note: *PowlVac ND® circuit breaker shown.*



Figure 13 *Circuit Breaker in Test Position*



Note: PowlVac® STD circuit breaker shown.

- 3) *Inserting the Circuit Breaker to the Connected Position*

The following emergency racking procedure is intended to be used only in the event of loss of control power, or failure of the ARM controller or ARM circuit breaker to operate electrically.

CAUTION

Prior to inserting the circuit breaker into the circuit breaker compartment, make sure that the control circuits are deenergized.

- a. Verify that the circuit breaker open/closed indicator displays **“BREAKER OPEN”** and if not, press the manual trip operator to open the circuit breaker.
- b. To insert the circuit breaker into the circuit breaker compartment, open the emergency racking drive shaft shutter (Figure 1, d) and place the racking handle socket onto the emergency racking drive shaft. The racking handle socket may be used to push down the shutter to gain access to the racking drive shaft.
- c. Turning the racking handle counterclockwise will begin to rack the circuit breaker into the compartment (Figure 16, a). When the circuit breaker is racked into the compartment, the force needed to rotate the racking handle will be low at the beginning of motion as the movement of the racking crank arms is only opening the shutters. Once the shutters are open, the circuit breaker begins to move toward the stationary primary disconnecting devices. When the movable primary disconnecting devices of the circuit breaker engage with the stationary

IMPORTANT

The preferred method of racking the ARM circuit breaker is electrically from a remote location utilizing the ARM controller installed in the switchgear. Refer to the ARM Controller instruction bulletin provided with the controller for detailed information on the automatic racking procedures.

IMPORTANT

In the event of an emergency, such as loss of ARM control power, the ARM circuit breaker is equipped with an emergency racking mechanism which enables racking the ARM circuit breaker into or out of the connected position.

primary disconnecting devices of the compartment, the force required to rotate the racking handle will increase appreciably. This force will decrease as the primary disconnecting devices spread and engage fully. Continuing rotation of the racking handle will cause the circuit breaker to travel further into the compartment ensuring wipe or overlap of the primary disconnecting devices. Continue racking until the breaker position indicator displays **"BREAKER CONNECTED"**. This will be approximately 22 rotations from the starting point. When the circuit breaker reaches the end of the racking travel, the user will notice an increased amount of force. If the operator continues to apply force, a torque limiter on the racking handle will produce a sharp clicking sound indicating the torque limit is reached at 35-ft-lb. Should the operator continue to apply force, the torque limiter will continue to operate with no further buildup of torque on the circuit breaker racking mechanism.

- d. Once the circuit breaker has reached the connected position, remove the racking handle, verify that the emergency racking drive shaft shutter has returned to its normal position, close the compartment door, and operate the circuit breaker as required.

Note: *This is the Connected Position.*

F. REMOVING THE CIRCUIT BREAKER FROM THE CIRCUIT BREAKER COMPARTMENT



Prior to removing the circuit breaker from the circuit breaker compartment, make sure that the control circuits are deenergized.



Prior to removing the circuit breaker from the circuit breaker compartment, make sure the circuit breaker is in the open position and all springs are discharged.

- 1) *Removing the Circuit Breaker from the Connected to the Test/Disconnected Position*
 - a. Verify that the circuit breaker open/closed indicator displays **"BREAKER OPEN"**. If **"CLOSED"**, close door and open breaker from a remote location or alternately by using the circuit breaker control switch on compartment door. Open door and verify that the circuit breaker open/closed indicator displays **"BREAKER OPEN"**.
 - b. With the compartment door open, press open the emergency racking drive shaft shutter. Place the racking handle socket onto the racking drive shaft shutter. The racking handle socket may be used to push down the shutter to gain access to the racking drive.
 - c. Turn the racking handle clockwise until the breaker position indicator displays **"BREAKER TEST/DISCONNECTED"**.
 - d. Remove the racking handle and verify that the manual trip operator has returned to its normal position.

Note: *This is the Test Position.*



- 2) *Removing the Circuit Breaker from the Test/Disconnected Position out of the Circuit Breaker Compartment*



CAUTION

Prior to removing the circuit breaker from the circuit breaker compartment, make sure that the control circuits are deenergized.



CAUTION

Prior to removing the circuit breaker from the circuit breaker compartment, make sure the circuit breaker is in the open position and all springs are discharged.

- a. Open the circuit breaker compartment door.
- b. Remove the circuit breaker compartment's secondary disconnect plug (Figure 12, c) by moving the secondary disconnect latch from right to left. Store the plug so it will not be damaged while withdrawing the circuit breaker.



CAUTION

Removal of the secondary disconnect plug will trip a closed breaker and discharge the main closing spring.

- c. Press the anti-rollout latch (Figure 20) to release the circuit breaker and pull the circuit breaker out of the circuit breaker compartment using the handles.

Ch 5 Maintenance

A. GENERAL DESCRIPTION



CAUTION

Prior to beginning any maintenance procedures, make certain that the control circuits are deenergized and the circuit breaker is resting securely outside the circuit breaker compartment. Do not work on a closed circuit breaker or a circuit breaker with the main closing spring charged.



IMPORTANT

Before attempting any maintenance work, it is important to study and fully understand the safety practices outlined in Chapter 2 of this instruction bulletin. If there is any reason to believe there are any discrepancies in the descriptions contained in this instruction bulletin, or if they are deemed to be confusing and/or not fully understood, contact Powell immediately.

1) Introduction

A regular maintenance schedule must be established to obtain the best service and reliability from the circuit breaker. PowlVac® circuit breakers are designed to comply with industry standards requiring maintenance every 1000 or 2000 operations depending upon the rating of the circuit breaker, or once a year.

Actual inspection and maintenance will depend upon individual application conditions such as number of operations, magnitude of currents switched, desired overall system reliability, and operating

environment. Any time the circuit breaker is known to have interrupted a fault current at or near its rating, it is recommended that the circuit breaker be inspected and the necessary maintenance be performed as soon as practical. Some atmospheric conditions such as extremes of dust, moisture, or corrosive gases might indicate inspection and maintenance at more frequent intervals. Very clean and dry conditions combined with low switching duty will justify longer times between inspection and maintenance operations. With experience, each user can set an inspection and maintenance schedule that is best suited for use.

If maintenance is performed at longer time intervals than one year, the vacuum integrity test should be performed each time the circuit breaker is removed from the metal-clad switchgear for reasons other than scheduled circuit breaker maintenance if it has been more than one year since the last vacuum integrity test.

A permanent record of all maintenance work should be kept, the degree of detail depending upon the operating conditions. The record will be a valuable reference for subsequent maintenance work and for station operation. It is also recommended that the record include reports of tests performed, the condition of circuit breakers, and any repairs or adjustments that were performed. This record should begin with tests performed at the time of installation and energization, and all data should be graphed as a function of time to ensure a proper maintenance cycle is being scheduled.



Because of extensive quality control tests made at the factory, the operations counter on a new circuit breaker will normally register over one hundred operations. The reading of the operations counter should be recorded when the circuit breaker is placed into service and when any maintenance work is performed.

2) *Inspection and Cleaning*



CAUTION

When cleaning the circuit breaker insulating supports and bus insulation, use only denatured alcohol or isopropyl alcohol to remove foreign material. Failure to do so may damage the dielectric and/or the mechanical properties of the insulation.

Visually check the circuit breaker for loose or damaged parts. Tighten or replace loose or missing hardware. Any damaged parts that will interfere with the normal operation of the circuit breaker should be replaced. This inspection will be much easier if the front cover and interphase barrier assembly are removed.

Clean the circuit breaker by removing any loose dust and dirt. Do not use compressed air to clean the circuit breaker. This may result in loose dirt or grit being blown into bearings or other critical parts, thus causing excessive wear. Use a vacuum cleaner, or wipe with a dry lint-free cloth or an industrial-type wiper to clean the circuit breaker. Do not use solvents, de-greasers, or any aerosol products to clean in the area of any mechanisms. Refer to **Ch 5 Maintenance, B. MECHANISM AREA, 2) Lubrication** for instructions on cleaning the lubricated areas for the stored energy mechanism and other specified parts.

Primary insulation, including the vacuum interrupter supports and the operating pushrods, should be cleaned. Wipe clean with a dry lint-free cloth or an industrial type wiper. If dirt adheres and cannot be removed by wiping, remove it with a mild solvent such as denatured alcohol. Be sure that the circuit breaker is dry before returning it to service. Do not use any type of detergent to wash the surface of the insulators as detergent may leave an electrically conducting residue on the surface as it dries.

B. MECHANISM AREA

1) *Mechanical Operation*

Remove the circuit breaker front cover to expose the stored energy mechanism. Make a careful visual inspection of the mechanism for loose, damaged, or excessively worn parts.

Note: *If timing tests are performed as in, **Ch 5 Maintenance, D. OPTIONAL MAINTENANCE PROCEDURES**, do not operate the circuit breaker until these tests are completed. Operation of the mechanism may alter the "As found" operating condition of the circuit breaker stored energy mechanism.*

*For further details, see **Ch 4 Installation, D. PLACING THE CIRCUIT BREAKER INTO SERVICE, 4) Mechanical Operation Check.***

2) Lubrication



Before applying any type of lubrication to the circuit breaker, the stored energy mechanism should be in the open position, and all springs should be discharged.

Powell offers a complete lubrication kit (Powlube-102) which contains all the lubricants required for maintaining the circuit breakers. Powlube-102 contains Rheolube 368A grease, Anderol 456 oil, and Mobilgrease 28.

Rheolube 368A grease should be lightly applied to those bearing surfaces that are accessible. Inaccessible surfaces, such as bearings, may be lubricated with a light synthetic machine oil such as Anderol 456 oil. Mobilgrease 28 should be applied to the electrical contact surfaces.

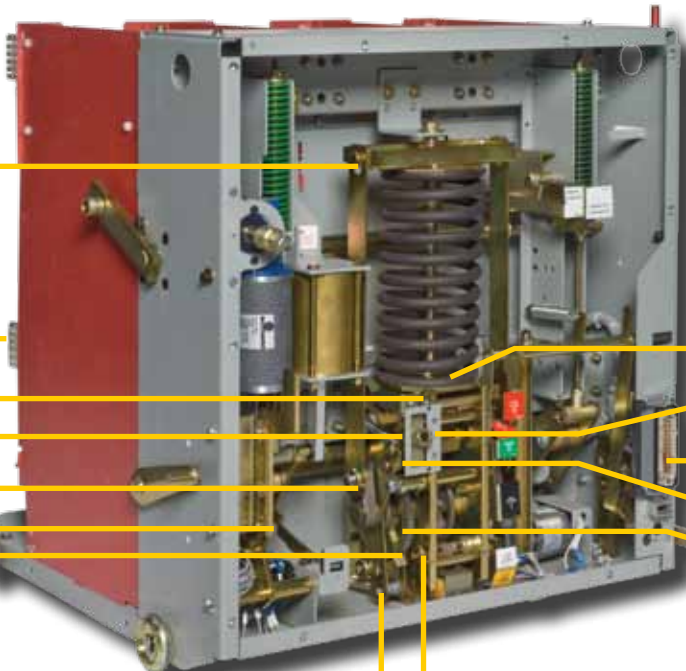
Lubricate the stored energy mechanism and other specified parts in accordance with *Table B, Lubrication*. See Figures 14 and 15 for labeled lubrication images.


Table B, Lubrication lists the location of all surfaces that should be lubricated, the type of lubricant to be used, and the method of applying the lubricant. The guiding rule in lubrication is to lubricate regularly, use lubricant sparingly and remove all excess lubricant. Tilting the circuit breaker will enable the lubricant to cover the bearing surfaces.


Table B Lubrication


Location	Reference Figure	Lubricant	Method
<i>Electrical Parts</i>			
Primary Disconnecting Device	Figure 14, b	Mobilgrease 28	Wipe clean. Apply lubricant only to actual contact surface.
Ground Connection	Figure 15, x	Mobilgrease 28	Wipe clean. Apply lubricant only to actual contact surface.
Secondary Disconnect Receptacle	Figure 14, g	Mobilgrease 28	Wipe clean. Apply lubricant only to actual contact surface.
<i>Mechanical Parts</i>			
Spring Yoke Pin	Figure 14, a	Anderol 456 Oil	
Primary Trip Prop Bearing	Figure 14, c	Anderol 456 Oil	Remove main closing spring.
Trip Shaft Bearing	Figure 14, d	Anderol 456 Oil	
Fundamental Linkage Pin	Figure 14, e	Anderol 456 Oil	Apply to penetrate where pin passes through end link.
Jackshaft Support	Figure 14, f	Anderol 456 Oil	
Pawl Support Arm	Figure 14, i	Anderol 456 Oil	
Crank Pin	Figure 14, h	Anderol 456 Oil	
Motor Drive Shaft Roller Needle Bearings	Figure 14, m	Anderol 456 Oil	
Pawls	Figure 14, k	Anderol 456 Oil	
Close Latch Shaft Face	Figure 14, n	Rheolube 368A Grease	Apply a light coating of grease and remove all excess.
Ratchet Wheel	Figure 14, l	Rheolube 368A Grease	
Jackshaft Lever Pins passing through Operating Pushrods	Figure 14, j	Anderol 456 Oil	Avoid lubricating on operating pushrods.
Main Closing Spring Guide Rod	Figure 15, o	Anderol 456 Oil	
Racking Mechanism	Figure 15, p	Anderol 456 Oil Rheolube 368A Grease	Apply Anderol 456 Oil to the crank arm rollers and racking crank arms. Wipe clean. Apply Rheolube 368A Grease to worn gear.
Primary Trip Prop Roller	Figure 15, q	Anderol 456 Oil	Remove main closing spring.
Secondary Linkage Roller	Figure 15, r	Anderol 456 Oil	Remove main closing spring.
Primary Trip Prop	Figure 15, s	Anderol 456 Oil	
Open-Close Flag Drive Lever Pin at Jackshaft	Figure 15, u	Anderol 456 Oil	
Flag Support Pin	Figure 15, v	Anderol 456 Oil	
Jackshaft Outer Bearing Support	Figure 15, w	Anderol 456 Oil	
Motor Drive Shaft Coupling	Figure 15, z	Anderol 456 Oil	
Wheel	Figure 15, ad	Anderol 456 Oil	
Motor Drive Shaft Support Bearings	Figure 15, ab	Anderol 456 Oil	
Camshaft Needle Bearings	Figure 15, aa	Anderol 456 Oil	
Close Shaft Support Bearing	Figure 15, y	Anderol 456 Oil	
Motor Cutoff Cam	Figure 15, ac	Rheolube 368A Grease	Apply to peripheral surface only.
Fundamental Linkage	Figure 15, t	Anderol 456 Oil	Apply to penetrate where pins pass through lines.

Figure 14 Lubrication







a. Spring Yoke Pin




b. Primary Disconnecting Device




c. Primary Trip Prop Bearing




d. Trip Shaft Bearing




e. Fundamental Linkage Pin




f. Jackshaft Support




g. Secondary Disconnect Receptacle




h. Crank Pin




i. Pawl Support Arm




j. Jackshaft Lever Pin




k. Pawls



l. Ratchet Wheel



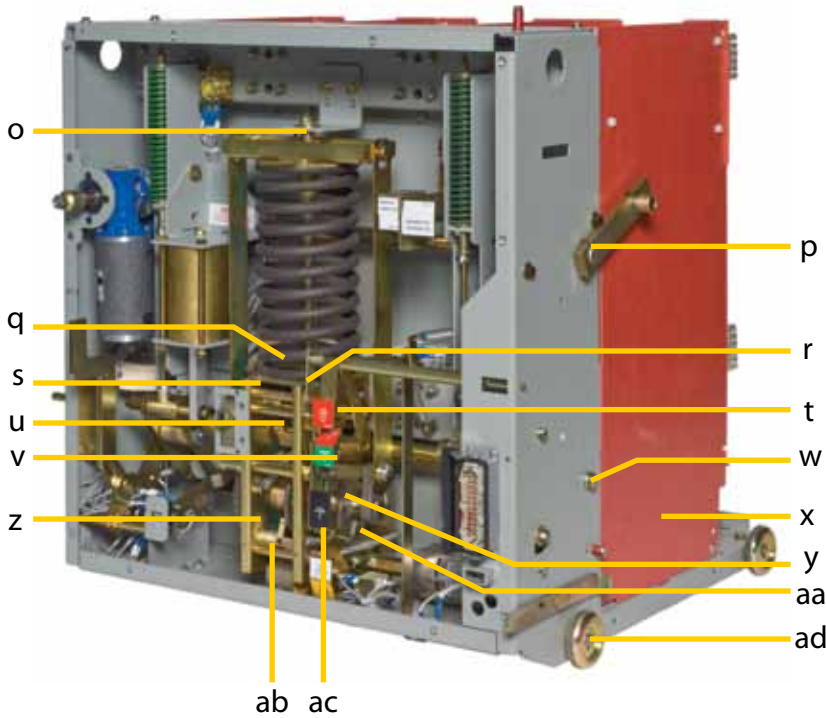
m. Motor Drive Shaft Roller Needle Bearings



n. Close Latch Shaft Face



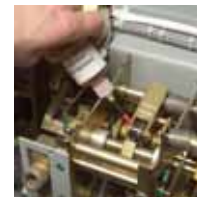
Figure 15 Lubrication (cont)



o. Main Closing Spring Guide Rod



p. Racking Mechanism



q. Primary Trip Prop Roller



r. Secondary Linkage Roller



s. Primary Trip Prop



t. Fundamental Linkage



u. Open-Closed Flag Drive Lever Pin at Jackshaft



v. Flag Support Pin



w. Jackshaft Outer Bearings Support



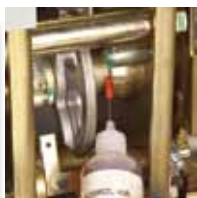
x. Ground Connection



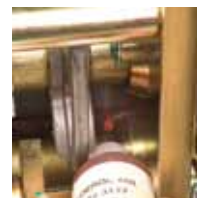
y. Close Shaft Support Bearing



z. Motor Drive Shaft Coupling



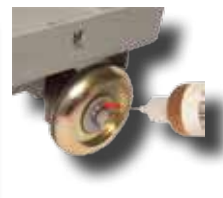
aa. Camshaft Needle Bearings



ab. Motor Drive Shaft Support Bearings



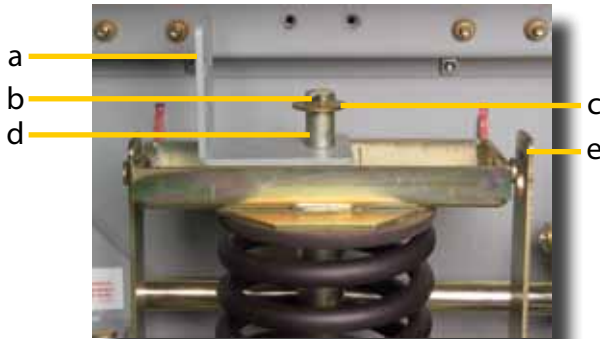
ac. Motor Cutoff Cam



ad. Wheel

3) Closing Spring Removal

Figure 16 Main Closing Spring Assembly Compressed for Removal

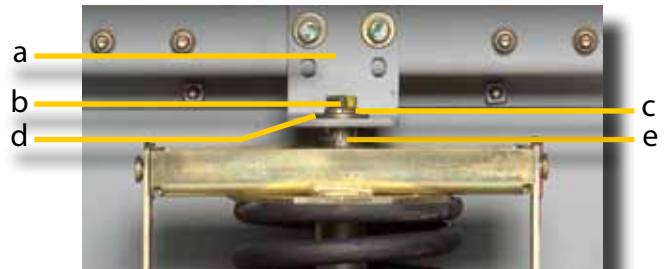


- a. Bracket
- b. Bolt
- c. Flat Washer
- d. Spacer
- e. Connecting Rod

The closing spring must be removed in order to perform slow closing of mechanism.

Although main closing spring removal is usually not necessary for lubrication, it may be necessary for performing adjustments or major overhaul tasks. Furthermore, removal of the main closing spring permits slow closing of the mechanism and the vacuum interrupter contacts. For details, see **Ch 5 Maintenance, B. MECHANISM AREA, 4) Slow Closing of Mechanism.**

Figure 17 Main Closing Spring Assembly Installed



- a. Bracket
- b. Bolt
- c. Lock Washer
- d. Flat Washer
- e. Spacer

The procedure for spring removal is as follows:

- a. With the main closing spring discharged and the circuit breaker contacts open, remove the bolt at the top of the spring rod together with the flat washer, and lock washer.
- b. Remove the horizontal bracket at the top of the main closing spring, by unfastening the two attachment bolts.
- c. Remove the spacer from below the bracket.
- d. Turn the bracket 90°, and replace it on the top of the spring yoke.
- e. Place the spacer above the bracket with the flat washer above the spacer.
- f. Insert bolt and tighten until the tension is taken off the connecting rods.
- g. With a slight rocking motion of the main closing spring assembly, the connecting rods (Figure 16, e) can now be unhooked from the spring yoke pins and the main closing spring assembly can be removed.

Note: Care should be taken on reassembly to ensure correct location of the flat washer, lock washer and spacer (Figure 17).

 **WARNING**

When any maintenance procedure requires the opening or closing of the circuit breaker or the charging of any of the stored energy mechanism springs, exercise extreme caution to make sure that all personnel, tools, and other miscellaneous objects are kept well clear of the moving parts or the charged springs. Failure to do this may cause serious damage or injury to the circuit breaker or personnel.

4) Slow Closing of Mechanism

The slow closing of mechanism described is not required for routine maintenance; however, it may be a useful procedure for troubleshooting circuit breaker misoperation.

- a. With the main closing spring assembly removed, rotate the camshaft so that the crank arms are pointing downward. The fundamental linkage will now move into the reset position.
- b. Push the manual close operator inward and hold it in while operating the charging handle to rotate the camshaft.
- c. When the close release latch arm has passed the close shaft latch plate, the manual close operator may be released. As the main closing cam engages the main cam roller, the jackshaft will commence to rotate.
- d. Continue to operate the charging handle until the crank arms point upward. The circuit breaker will now be closed and there will be a gap between the operating pushrod lock nuts and the pivot blocks.
- e. Return the circuit breaker to the open position by depressing the manual trip operator.

- f. To install the main closing spring assembly reverse the preceding removal procedure.

5) Mechanism Adjustments

Several factory adjustments in the stored energy mechanism are described in this section. **NO ADJUSTMENT OF THESE SETTINGS IS REQUIRED FOR ROUTINE MAINTENANCE**, but they may need to be adjusted after a major overhaul or removal of the mechanism.

Note: *Do NOT adjust these settings unnecessarily, as damage to the circuit breaker may occur.*

a. Adjustment of Ratchet Wheel Holding Pawl

The holding pawl support arm (Figure 2, s) is adjusted by the holding pawl adjusting eccentric (Figure 2, u).

If the pawl is not properly adjusted, there will be a “knocking” noise when the ratchet mechanism is operating or the stored energy mechanism will not ratchet at all.

To adjust the pawl perform the following steps:

1. Remove the escutcheon to gain access to the head of the bolt holding the adjusting eccentric.
2. Loosen the bolt slightly.
3. Grip the eccentric with a pair of slip-joint pliers or a similar tool and rotate the stop slightly.
4. Tighten the holding bolt with the eccentric in the new position.
5. While charging the main closing springs, using the charging motor

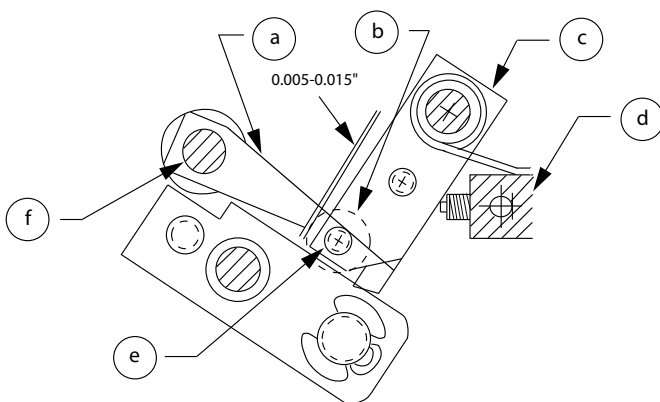
to drive the mechanism, observe the ratcheting operation for improvement.

6. If the ratcheting operation has not improved, repeat the preceding sequence until the ratcheting operation is smooth. This may require several charging cycles.
7. When the eccentric is properly set replace the escutcheon.

Be sure that the escutcheon is reinstalled on the proper circuit breaker, since the escutcheon contains the nameplate with the circuit breaker rating and serial number information. The serial number of the circuit breaker is also attached to the circuit breaker frame near the ground connection on an engraved serial number metal plate. The serial number found on the nameplate must match the number affixed to the frame.

b. Adjustment of Primary Trip Prop

Figure 18 Primary Trip Prop Adjustment



- a. Secondary Trip Prop
- b. Primary Trip Prop Roller
- c. Primary Trip Prop
- d. Primary Trip Prop Adjusting Screw
- e. Rivet
- f. Trip Bar

Perform the following procedures to adjust the primary trip prop:

1. Remove the main closing spring. Refer to **Ch 5 Maintenance, B. MECHANISM AREA, 3) Closing Spring Removal**
2. Adjust the primary trip prop adjusting screw (Figure 18, d) so that with the fundamental linkage in the reset position, the clearance between the primary trip prop roller and the secondary trip prop is 0.005" to 0.015". The primary trip prop adjusting screw is accessible from the rear of the stored energy mechanism and is located inside the hole beside the lower middle insulator supporting the live part assembly.
3. Replace the main closing spring.

c. Tripping System Adjustment

WARNING

Prior to performing any adjustment or maintenance procedure, all high voltage components shall be deenergized, disconnected by means of a visible break, and securely grounded.

To adjust the PowlVac® STD Tripping System perform the following steps:

1. Prior to performing this adjustment procedure, all high voltage components shall be deenergized, disconnected by means of visible break and securely grounded, and ensure that the control circuits are deenergized.
2. Remove the circuit breaker front cover.



3. Loosen the secondary trip prop adjusting screw locking nut several full turns (Figure 20, d).

CAUTION

Do NOT allow the secondary trip prop adjusting screw to turn while loosening the locking nut. Failure to observe this caution will severely damage the mechanism.

4. Manually charge the circuit breaker main spring.
5. Manually CLOSE the circuit breaker.
6. Slowly turn the secondary trip prop adjusting screw (Figure 20, c) clockwise in 1/8 turn (45°) increments until the breaker trips OPEN. Carefully note the rotational position of the tool used to turn the adjusting screw at the moment the breaker operates. Do NOT turn the screw any further clockwise after the breaker operates.
7. Turn the secondary trip prop adjusting screw counter-clockwise 1½ full turns from the position noted in step 6.
8. While holding the secondary trip prop adjusting screw from turning, securely tighten the secondary trip prop adjusting screw locking nut.
9. Manually charge the main closing spring using the manual charge handle per **Ch 4 Installation, D. PLACING THE CIRCUIT BREAKER INTO SERVICE, 4) Mechanical Operation Check.**
10. Manually CLOSE the circuit breaker.
11. Using leaf type feeler gauges with a total of 0.090" thickness selected, position the feeler gauge as shown in Figure 19.

Figure 19 Feeler Gauge



12. Slowly depress the trip coil armature using the manual charge handle. Position the handle as shown in Figure 19. Depress the handle until the armature contacts the feeler gauges. The circuit breaker should not trip.

Note: Do NOT tilt the armature. Tilting the armature by applying a load to the right of the feeler gauges will produce incorrect results.

13. Choose one of the following steps according to the TRIP status:
 - i. If the circuit breaker TRIPPED during the test performed in step 12, increase the gap between the trip coil armature and the trip lever by bending the trip lever downwards slightly using channel lock pliers or a small crescent wrench. Repeat steps 9 through 12.

Note: Bend the trip lever in very small increments. This process may take several attempts.

- ii. If the circuit breaker did NOT TRIP during the test performed in step 12, reset the feeler gauges with 0.030" selected and position the feeler gauge as shown in Figure 19.
- 14. Slowly depress the trip coil armature using the manual charge handle. Position the handle as shown in Figure 19. Depress the handle until the armature contacts the feeler gauges. The circuit breaker should trip.

Note: Do NOT tilt the armature. Tilting the armature by applying a load to the right of the feeler gauges will produce incorrect results.

- 15. If the circuit breaker did not TRIP during the test performed in step 14, remove the feeler gauges and trip the breaker. Decrease the gap between the trip coil armature and the trip lever by bending the trip lever upwards slightly using channel lock pliers or a small crescent wrench. Repeat steps 9, 10, and 14.

Note: Bend the trip lever in very small increments. This process may take several attempts.

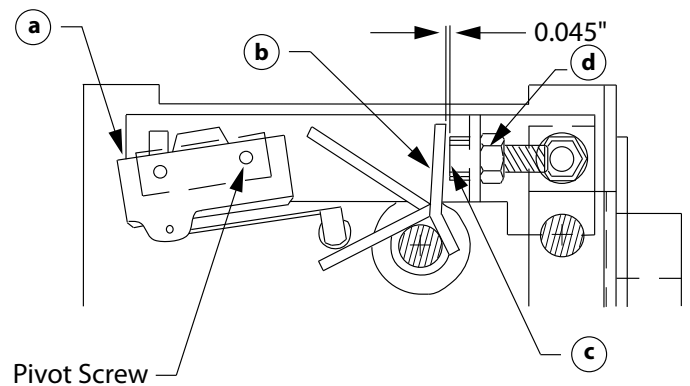
- 16. Repeat steps 9 through 15 until the breaker does not trip with the 0.090" gauge inserted in the trip coil armature gap and does trip with the 0.030" gauge inserted into the trip coil armature gap.
- 17. Manually CLOSE and TRIP the circuit breaker so that all springs are discharged.

- 18. Perform the latch check switch adjustment per the procedure found in **Ch 5 Maintenance, B. MECHANISM AREA, 4) Slow Closing of Mechanism, d. Latch Check Switch Adjustment.**
- 19. Replace circuit breaker front cover.

d. Latch Check Switch Adjustment

The latch check switch adjustment (Figure 20) described is not required for routine maintenance; however, the latch check switch may need to be adjusted after major overhaul, removal of the mechanism, or tripping system adjustment.

Figure 20 Latch Check Switch Adjustment



- a. Latch Check Switch
- b. Latch Check Operator
- c. Secondary Trip Prop Adjusting Screw
- d. Secondary Trip Prop Adjusting Screw Nut

To adjust the latch check switch perform the following steps:

- 1. Remove the main closing spring Refer to **Ch 5 Maintenance, B. MECHANISM AREA, 3) Closing Spring Removal.**
- 2. Rotate the crank arms until the spring charge indicator displays, CLOSING SPRING CHARGED.



3. Loosen the two screws which secure the latch check switch and rotate the latch check switch about the pivot screw downward to the lowest position allowed. The latch switch contacts are now OPEN.
4. Insert a 0.045" gauge between the secondary trip prop adjusting screw (Figure 20, c) and latch check operator. Rotate the latch check switch upwards until the contacts are closed. (An audible click of the contacts will be heard). At the position where the click is heard hold the switch and retighten the two screws which secure the latch check switch. Remove the gauge.
5. To confirm that the latch check switch is properly set, slowly depress and release the manual trip operator to verify that the latch check switch OPENS and CLOSSES properly. (An audible click of the contacts will be heard). The latch check switch contacts will OPEN as the latch check operator is moved by the manual trip operator away from the secondary trip prop adjusting screw. Slowly withdraw the manual trip operator and the latch check switch contacts should close when the latch check operator is between 0.045" to 0.015" away from the secondary trip prop adjusting screw.
6. Depress the manual close operator and rotate the crank arm until resistance is felt.
7. Depress and hold the manual trip operator inward and rotate the crank arms until the spring charge indicator displays, CLOSING SPRING DISCHARGED.
8. Reinstall the circuit breaker main closing spring.

e. Adjustment of Close Latch Shaft

The close latch shaft (Figure 2, aa) passes through the side sheets of the stored energy mechanism frame at the front of and below the cam shaft. One end of the shaft is shaped to make a latch face and interferes with the close latch arm (Figure 2, y), which is fixed to the cam shaft. The other end of the close latch shaft is attached to a lever positioned by a close bar adjusting screw (Figure 2, ae).

To adjust the close latch shaft perform the following procedures:

1. Remove the escutcheon.
2. Loosen the locking nut from the close bar adjusting screw while holding the position of the close bar adjusting screw with a screw driver.
3. Back out the close bar adjusting screw by turning the screw counterclockwise 2 full turns.
4. Manually charge the circuit breaker main closing spring with a manual charging handle until the spring charge indicator displays CLOSING SPRING CHARGED.
5. Turn the close bar adjusting screw clockwise until the main closing spring discharges, then depress the manual trip operator to OPEN the circuit breaker.
6. Turn the close bar adjusting screw 3 to 3½ full turns counterclockwise. Retighten the locking nut holding the screw.
7. Repeat step 5. Then CLOSE and OPEN the circuit breaker to ensure proper operation.
8. Replace the escutcheon.

6) *Electrical Operation*

After performing any necessary mechanical and lubrication maintenance, operate the circuit breaker electrically several times to ensure that the electrical control system works properly. See **Ch 4 Installation, D. PLACING THE CIRCUIT BREAKER INTO SERVICE, 5) Electrical Operation Check.**

3) *Mechanical Adjustment of Vacuum Interrupters*

There are no adjustments required for routine maintenance of a vacuum interrupter assembly. There are several factory adjustments which will vary over the operating life of the vacuum interrupter.

C. VACUUM INTERRUPTER AND CONTACT AREA

1) *Vacuum Interrupter and Contact Erosion*

At each inspection the vacuum interrupters should be checked for contact erosion. The circuit breaker must be closed for this check. Each new vacuum interrupter is set with a gap of about 1/4" to 5/8" between the contact loading spring yoke and the lock nut on the operating pushrod stud. As the contacts erode with use, this gap will decrease. Because the factory setting of the lock nut gap varies for each vacuum interrupter, a label is provided on the lower part of each vacuum interrupter. The original factory setting of the gap and the end-of-life measurement of this gap is recorded on the label. When the gap measurement reaches the end-of-life value given on this label, the vacuum interrupter should be replaced.

2) *Vacuum Integrity*

Refer to **Ch 4 Installation, D. PLACING CIRCUIT BREAKER INTO SERVICE, 2) Vacuum Integrity** for information on vacuum integrity and testing of vacuum interrupters.



CAUTION

Adjustments of these settings are only necessary when repair requires the removal or replacement of the vacuum interrupter. Do not adjust these settings unnecessarily as damage to the circuit breaker may result.

When it is necessary to remove or replace the vacuum interrupter it should only be done by a qualified technician or a Powell service technician. Contact Powell for further assistance at 1.800.480.7273.

D. OPTIONAL MAINTENANCE PROCEDURES

1) *High Potential Tests*

High potential tests are not required for routine maintenance but are recommended after a heavy fault interruption, any major circuit breaker repair that involves the primary current path or when the circuit breaker has been in storage for an extended time, especially in a damp location or other adverse environment. In these cases, both the High Voltage Insulation Integrity and Control Voltage Insulation Integrity tests should be performed. Refer to **Ch 4 Installation, D. PLACING CIRCUIT BREAKER INTO SERVICE**, for details of these procedures.



2) Timing

At normal control voltage, operate the test source to the “close” position to close the circuit breaker and record the closing time. The closing time from energizing the closing coil to vacuum interrupter contact touch should not exceed the values in the timing table. Again, at normal control voltage, operate the test source to the “open” position to open the circuit breaker and record the opening time. The opening time from energizing the shunt trip coil to vacuum interrupter contact part should not exceed the values in the timing table.

Table C Timing

	Closing Time	Tripping Time
3 Cycle	≤80 ms	<35 ms
5 Cycle	≤80 ms	<50 ms

3) Primary Resistance Check

This check is not required for routine maintenance but it is recommended after any major maintenance that requires disassembly of any part of the primary current path.

To check the resistance, pass a minimum of 100A DC through the circuit breaker pole, with the circuit breaker closed. Measure the voltage drop across the primary contacts and calculate the resistance. The resistance should not exceed the values provided in this instruction bulletin for the specific type and rating of the circuit breaker being measured.

When making this test, be sure that the test current passes through both main horizontal primary disconnecting devices of each pair, or the resistance measurement will be affected. This may be done by

connecting the current source leads to two blocks of full round edge copper 1” thick by 3” or 4” wide by 4” long, and pressing these blocks into the upper and lower primary disconnecting devices of the circuit breaker compartment. The voltage drop measurement may be made between these two blocks.

The micro-ohm values of resistance must not exceed the following limits:

Table D Primary Resistance

Breaker Type	Rated (kV)	Rated Continuous Current A	Resistance Micro-ohms
05PV36ARM	4.76	1200	60
05PV36ARM	4.76	2000	50
05PV50ARM	4.76	1200	60
05PV50ARM	4.76	2000	45
05PV50ARM	4.76	3000	40
15PV25ARM	15	1200	70
15PV25ARM	15	2000	50
15PV36ARM	15	1200	60
15PV36ARM	15	2000	50
15PV50ARM	15	1200	60
15PV50ARM	15	2000	45
15PV50ARM	15	3000	40

Ch 6 Recommended Renewal Parts and Replacement Procedures

A. ORDERING INSTRUCTIONS

1. Order Renewal Parts from Powell at www.powellind.com or call 1.800.480.7273.
2. Always specify complete nameplate information, including:
 - Circuit Breaker Type
 - Serial Number
 - Rated Voltage
 - Rated Amps
 - Impulse Withstand
 - Control Voltage (for control devices and coils)
3. Specify the quantity and description of the part and the instruction bulletin number. If the part is in any of the recommended renewal parts tables, specify the catalog number. If the part is not in any of the tables, a description should be accompanied by a marked illustration from this instruction bulletin, a photo or simply submit a sketch showing the part needed.

B. RECOMMENDED RENEWAL PARTS

A sufficient amount of renewal parts should be stored to enable the prompt replacement of any worn, broken or damaged part. A sufficient amount of stocked parts minimizes service interruptions caused by breakdowns and saves time and expense. When continuous operation is a primary consideration, a larger quantity of renewal parts should be stocked depending on the severity of the service and the time required to secure replacement parts.

Since parts may be improved periodically, renewal parts may not be identical to the original parts. *Tables E, F, and G* list the

recommended spare parts to be carried in stock by the user. The recommended quantity is not specified. This must be determined by the user based on the application. As a minimum, it is recommended that one set of parts be stocked per ten circuit breakers or less.

Powell recommends that only qualified technicians perform maintenance on these units. Refer to the Qualified Person Section in the front of this instruction bulletin. If these circuit breakers are installed in a location where they are not maintained by a qualified technician, a spare circuit breaker should be on site ready for circuit breaker replacement. The malfunctioning unit can then be returned to the factory for reconditioning.

C. REPLACEMENT PROCEDURES

This section includes instructions for replacing the parts recommended as renewal parts. Before attempting any maintenance repair work, take note of the safety practices outlined in **Ch 2 Safety** of this instruction bulletin.



CAUTION

Ensure that the control circuits are deenergized and the circuit breaker is deenergized, disconnected by means of a visible break, and securely grounded. Do NOT start to work on a closed circuit breaker or a circuit breaker with the main closing spring charged. When any maintenance procedure requires the opening or closing of the circuit breaker or the charging of any of the stored energy mechanism springs, exercise extreme caution to ensure that all personnel, tools, and other miscellaneous objects are kept clear of the moving parts of the charged springs.



1) Vacuum Interrupter Assembly



CAUTION

The vacuum interrupter should only be replaced by a qualified person or a Powell Service technician. Contact Powell for further assistance at 1.800.480.7273.

2) Sliding Contact Finger Assembly

To clean, inspect, and lubricate the sliding contact finger assemblies (Figure 21), remove the four socket head screws holding the sliding contact finger assemblies and pivot the assemblies down. Wipe the lubrication from the surfaces of the lower contact block, sliding contact fingers, and the lower primary disconnecting devices and examine the surfaces. The sliding contact finger locations should present a burnished silver contact without copper appearance at more than one location. If the copper is visible at more than one location per pole or the silver is torn on the lower contact block, the vacuum interrupter assembly should be replaced.

The sliding contact finger assemblies on the PowVac® circuit breakers are reversible. Since only the upper ends of the fingers experience any wiping action, the wear is normally confined to that end. If the upper ends of the fingers show noticeable wear, the finger assemblies can be reversed. Loosen the bolt holding the rear mounting clip and remove the finger assembly. Invert the assembly and replace it in the mounting clips. Tighten the bolt holding the rear mounting clip. If copper is visible at more than one contact location on a finger assembly, that assembly should be replaced. Apply a light coat of Mobilgrease

28 contact lubricant to both sides of the contact blocks and to the contact areas of the lower primary disconnecting devices, then reassemble the sliding contact finger assemblies by replacing the four socket head screws and tighten to a torque value of 8-12 lb-ft.

3) Closing Coil Assembly

Refer to *SM-1300 Closing Coil Assembly* for replacement and installation procedures.

4) Primary Shunt Trip Coil Assembly

Refer to *SM-1600 Primary Shunt Trip Coil Assembly* for replacement and installation procedures.

5) Secondary Shunt Trip Coil Assembly

Refer to *SM-1700 Secondary Shunt Trip Coil Assembly* for replacement and installation procedures.

6) Undervoltage Device Assembly (UV)

Refer to *SM-1800 Undervoltage Assembly* for replacement and installation procedures.

7) Charging Motor Assembly

Refer to *SM-1200 Charging Motor Assembly* for replacement and installation procedures.

8) Anti-Pump Relay Assembly

Refer to *SM-1000 Anti-Pump Relay Assembly* for replacement and installation procedures.

9) Latch Check Switch

Refer to *SM-1400 Latch Check Switch Assembly* for replacement and installation procedures.

10) Motor Cutoff Switch Assembly

Refer to *SM-1500 Motor Cutoff Switch Assembly* for replacement and installation procedures.

11) Auxiliary Switch

Refer to *SM-1100 Auxiliary Switch Assembly* for replacement and installation procedures.

12) Primary Disconnecting Device Spring Assembly

This assembly is located at the outer end of the primary disconnecting device.

- a. Depress the spring support sufficiently to allow keeper to be removed.
- b. Remove the spring and the spring.
- c. Slide the spring onto the spring support, and place the spring support in the appropriate slot in the primary disconnecting devices.
- d. Depress the head of the spring support and install the keeper in the end of the spring support.
- e. Release the spring slowly, allowing keeper to seat properly.

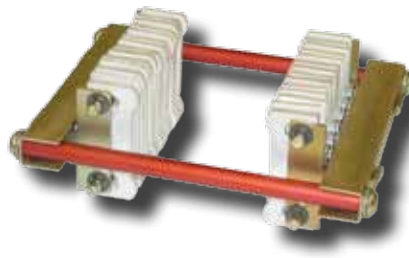


Table E Primary Current Path							
Breaker Type k factor = 1	Rated kV	Rated Continuous Current (Amperes)	Sliding Contact Finger Assembly	Primary Disconnecting Device (Upper)		Primary Disconnecting Device (Lower)	Vacuum Interrupter Assembly
				Left	Right		
05PV36ARM	4.76	1200	50952G01P	50403P04		60501G02P	
		2000		50403P01			
05PV50ARM	4.76	1200	50956G01P	50403P01		60501G03P	
		2000	50956G02P				
		3000					
15PV25ARM	15	1200	50952G01P	50403P04		60501G01P	
		2000		50403P01			
15PV36ARM	15	1200	50952G01P	50403P04		60500G01P	
		2000		50403P01			
15PV50ARM	15	1200	50956G01P	50403P01		60500G03P	
		2000	50956G02P				
		3000					

Figure 21 Primary Current Path



Primary Disconnecting Device



Sliding Contact Finger Assembly



Vacuum Interrupter Assembly

Table F Control Devices

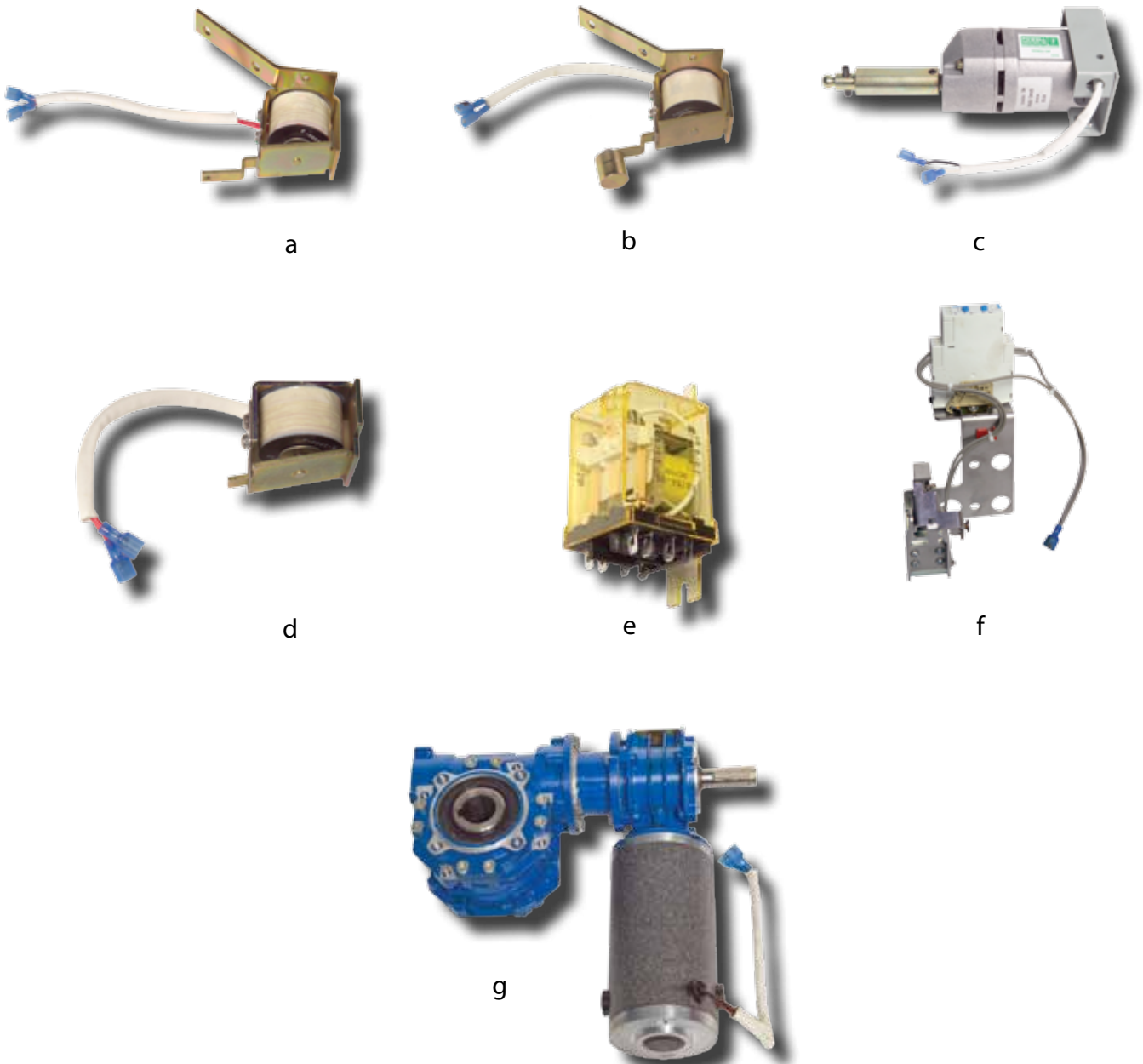
Control Voltage	Primary Shunt Trip Coil Assembly (2)		Secondary Shunt Trip Coil Assembly (3)	Undervoltage Device Assembly (4)	Charging Motor Assembly	Anti-Pump Relay (5)	Closing Coil Assembly	Racking Motor
	3-Cycle	5-Cycle						
24VDC	50027G05P	50041G08P	50042G06P	50028G08P	n/a	n/a	n/a	n/a
48VDC	50027G01P	50041G01P	50042G01P	50028G07P	50960G06P	RR2BA-US-DC48V	50026G01P	n/a
125VDC	50027G02P	50041G02P	50042G03P	50028G10P	50960G04P	RR2BA-US-DC110V	50026G03P	509140
250VDC	50027G03P	50041G03P	50042G04P	50028G06P	50960G05P	RR2BA-US-DC110V	50026G04P	n/a
120VAC	50027G01P	50041G05P	50042G01P	n/a	50960G04P	RR2BA-US-AC120V	50026G01P	n/a
240VAC	50027G06P	50041G06P	50042G02P	n/a	50960G05P	RR2BA-US-AC240V	50026G02P	n/a
Capacitor Trip (6)	50027G04P	50041G04P	50042G05P	n/a	n/a	n/a	n/a	n/a

Notes:

- 1) One required per circuit breaker if the circuit breaker was originally equipped with this item. All circuit breakers have a closing coil, primary shunt trip coil, charging motor, and an anti-pump relay assembly. Secondary shunt trip coils and undervoltage device assemblies are optional (see notes 2-7).
- 2) Primary shunt trip coil is available as a 3 cycle and 5 cycle control device. Trip coil assemblies must only be replaced with the same type as originally supplied.
- 3) Secondary shunt trip coil cannot be furnished with an undervoltage device assembly.
- 4) Where furnished, cannot be present with secondary shunt trip coil assembly.
- 5) For 250VDC applications, a dropping resistor 50747G02P is required in series with the anti-pump relay assembly.
- 6) For use with capacitor trip units with 240VAC input. Consult factory for other circuit breaker ratings.
- 7) All control devices are available with push-on terminals. Consult factory for control devices with screw terminals.



Figure 22 Control Devices



- a. Primary Shunt Trip Coil (3 cycle)
- b. Primary Shunt Trip Coil (5 cycle)
- c. Charging Motor Assembly
- d. Closing Coil Assembly
- e. Anti-Pump Relay
- f. Undervoltage Device Assembly
- g. Racking Motor

Table G Miscellaneous Parts

Description	Catalog Number	Illustration
<i>Auxiliary Switch</i>		
Push-On Terminals	102108LN	
Screw-On Terminals	102108LP	
<i>Ground Connection</i>		
25kA	50951G02P	
36kA	50952G03P	
50kA	50952G02P	
<i>Latch Check Switch</i>		
BA-2RV2-A2		
<i>Motor Cutoff Switch Assembly</i>		
50756G03P	Image Not Available	
<i>PowlVac® Hardware Kit</i>		
6050G24		
<i>PowlVac® Lubrication Kit</i>		
Powlube-102		
<i>Operating Pushrod Assembly</i>		
25kA	50934G18P	
36kA	50934G19P	
50kA	50934G20P	
<i>Racking Motor</i>		
509140		



IB-51056
PowlVac[®] ARM Automatic
Racking Vacuum Circuit Breaker

5kV & 15kV
1200A, 2000A, & 3000A

January 2011